

# The complete guide to selling, surveying and specifying UltraRoof380

DECEMBER 2016 | V1



## WHY CHOOSE ULTRAROOF380?

The UltraRoof380 is pre-manufactured by Ultraframe to ensure consistent quality and a speedy installation with less waste.



01

### **MOST THERMALLY EFFICIENT ROOF ON THE MARKET!**

- Reduce heating bills with a comfortable temperature all year
- UltraRoof380's 0.16 U-value is 15 times more thermally efficient than typical old conservatory
- New frames and glazing will increase these benefits even further

02

### **INTEGRATED FULL LENGTH GLASS**

- Full length glass panels give more light than a Velux roof light
- It's much cheaper than inserting Velux windows - although the roof can be prepared for Velux roof lights
- Project light into an adjacent room or maximise the light into the room by choosing the location of the glass panels.

Go to page 8 to find out more about glazing options.

03

### **FAST TO FIT**

- Can be watertight and tiled within 6 hours with much less disruption for the homeowner
- Labour savings mean lower costs for the homeowner and the retailer.

04

### **NO RED TAPE!!**

- Ultraframe have partnered with jhai to provide the necessary Building Regulation completion certificates (England & Wales).
- This simple way of complying with Building Regulations is practical, pragmatic and saves costs for the homeowner and retailer.

To find out more about Building Regulations for UltraRoof380 go to page 19.

05

### **MOST AUTHENTIC LOOKING TILE ON THE MARKET!**

- The UltraTile looks more like slate than any other replica tile
- Available in Slate Grey, Harvest Brown and Terra Brick Red, the tiles match the vast majority of UK houses.

For tiling and colour options go to pages 13-15.

06

### **ALL THE DESIGN FLEXIBILITY YOU'D EXPECT FROM ULTRAFRAME**

- Spotlights can be added to the perimeter pelmet or pendant lighting can be added to the centre of your new room.
- Choose from a range of colours for your gutters, fascia and soffits
- Combine UltraRoof380 with Loggia Super Insulated columns for a distinctive finish and improved thermal performance.

To find out more about additional options for UltraRoof380 go to page 12-16.

**REMEMBER, NO TIE BAR.... EVER!!!**

# CONTENTS

ULTRAROOF380 SYSTEM OVERVIEW	4	1 SALES
CHECKLIST FOR SALES PEOPLE	5	
<b>4 STAGE SALES AND DESIGN PROCESS</b>	<b>6 - 15</b>	
<b>STEP 1 LAYOUT - THINGS TO CONSIDER</b>	6	
<b>LAYOUT PLAN</b>	7	
<b>STEP 2 ROOF GLAZING</b>	8 - 9	
<b>STEP 3 ROOF STYLE -SHAPE</b>	10 - 11	
<b>ROOF STYLE - RIDGE AND HIP BAR</b>	12	
<b>STEP 4 FINISHING TOUCHES - COLOUR</b>	13 - 15	
<b>FINISHING TOUCHES - PELMET LIGHTING</b>	16	
4 STAGE SALES AND DESIGN PROCESS		
CHECKLIST FOR SURVEYORS	17 - 18	2 SURVEYORS
PRINCIPLES OF REPLACING CONSERVATORY ROOFS	19	
ASSESSING THE EXISTING CONSERVATORY	20 - 21	
ULTRAROOF380 SURVEYING GUIDELINES	22	
EXAMINING THE HOST WALL	23	
CALCULATING THE ROOF SIZE	24	
USEFUL POINTS TO REMEMBER FOR SPECIFIERS	25	3 SPECIFIERS
PRODUCT ASSEMBLIES	26-28	
ROOF GLAZING	29	
INTEGRATED GLAZING RULES	30 - 33	
CHOOSING APPROPRIATE BOX GUTTER AND SUPPORT	34	
ROOF SITUATION EXAMPLES	35	
VELUX WINDOWS	36	
- ROOF WINDOWS SIZE CODE	36	
- GEORGIAN ROOF WINDOW OPTIONS	37 - 39	
- HIPPED LEAN TO WINDOW OPTIONS	40 - 41	
- GABLE WINDOW OPTIONS	42	
MAXIMUM ROOF SIZES AND STRUCTURAL PERFORMANCE	43	
STRUCTURAL LOADS - WORKED EXAMPLE	44	
STRUCTURAL SPECIFICATION	45 - 46	
STRUCTURAL SUPPORT	47	
STANDARD SUPPORT FOR STANDARD BOX BEAM	48	
STANDARD SUPPORT FOR TAPERED BOX GUTTERS	49	
BOX BEAM STRUCTURAL SUPPORT FOR 265 BOXGUTTER	50	
STRUCTURAL SUPPORT - GALLOWS BRACKET - BUNGALOW SITUATION	51	
GALLOW'S BRACKET	52	
- CORNER	52	
- INTERMEDIATE	53	
STRUCTURAL SUPPORT - TIMBER STUD WORK	54 - 56	
INTRUSIONS	57 - 61	
BOX BEAM ON WINDOW FRAME	62	
BOX BEAM ON BRICK WORK	63	
BOX BEAM ON BRICK AND WINDOW FRAME	64	
SOFFIT WIDTHS	65	
SOFFIT WIDTH RELATIVE TO EXTERNAL FRAME	66	
SOFFIT RELATIVE TO BRICK WORK	67	
JOINING TWO BEAMS	68 - 69	
INTERNAL BRICK BEAM JOINT	70	
SUPPORTING JOINT ON POST	71	
INTERNAL JOINT ON POST	72	
FIXING PLATE	73	
BOX BEAM ON LOGGIA COLUMN	74	
UNCOMMON INSTANCES - GEORGIAN ROOF ON VICTORIAN FRAMES	75	
OUT OF SQUARE ROOFS	76	
CONVERTING EXISTING CONSERVATORY WITH BOXGUTTER TO ULTRAROOF380	77 - 82	
APPROPRIATE FIXINGS / CAVITY TRAY ASSESSMENT / VERTICAL DCP REQUIREMENT	83	



# ULTRAROOF380 OVERVIEW

## Product definition

UltraRoof380 is a solid roof, perfect for the speedy replacement of tired conservatory roofs. It is a packaged solution, off site manufactured for rapid assembly and compliant with relevant Building Regulations. UltraRoof380 is classed as a 'warm roof' and gives a vaulted/loft type ceiling. There are three major elements to UltraRoof380;

**#1**



### INSULATED BEAMS

A patented box eaves beam, filled with EPS beads as used in cavity insulation - that forms the soffit structure - approx 380mm front to back depth.

**#2**

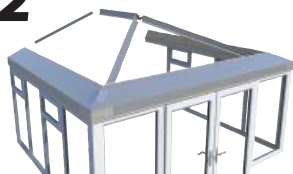

### ALUMINIUM FRAMEWORK

A hidden structural aluminium framework for hips, ridge and starter bars.

**#3**

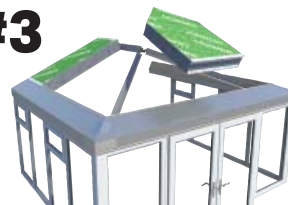

### STRUCTURAL ROOF PANELS

Mechanically fixed Kingspan Unidek Aero Structural Insulated Roof Panels are attached to the box eaves and structural framework.

The roof comes with the counter battens already fixed. Tongue and grooved 12mm OSB is then fixed before a self adhesive, high performance water proofing layer is laid. UltraTile engineered copolymer interlocking tiles sheet (12 slates per sheet) are then laid across the roof slope.

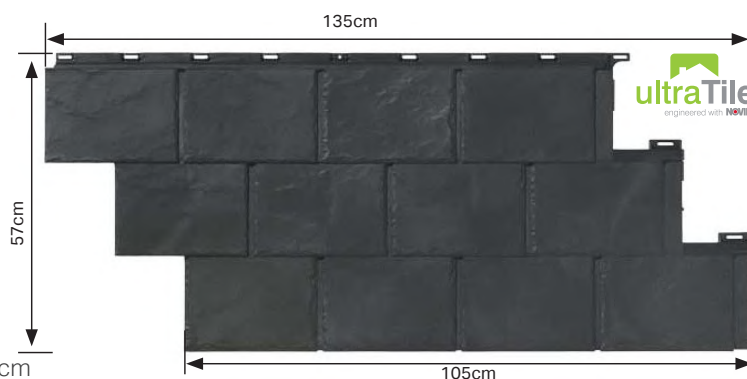

**Overall dimensions:** 135.3 cm x 57.15 cm x 1.9 cm  
**8 panels per box :** approximately 4,65 m<sup>2</sup> / 0,58 m<sup>2</sup> per panel

### Key performance criteria/simplified rules

- The product can be designed with window frames to all elevations - no support posts.
- If bi-folding doors are to be used they MUST be bottom supported NOT top hung.
- The standard soffit projects approx 40mm beyond the external face of the window frame - box eaves beam is approx 380mm front to back depth.
- Pitch range - minimum is 12.5° on lean to and 15° on duo pitch - maximum pitch is 40°.
- Pitch must be equal to all sides - on 3/5 bay Victorians facet sizes must be equal size / angle.
- System 'U' values - with the 190mm Unidek Aero panels is 0.16W/m<sup>2</sup>C.
- Rectangular glass panels can be integrated to maintain light into any adjacent room. Alternatively, add one of 4 Velux roof windows/sizes.
- Everything is pre-fabricated in our highly efficient factory to ensure rapid one day fit on site.
- On a 4m x 4m Georgian, the system weight is 38kg/M<sup>2</sup> including plasterboard (12kg/m<sup>2</sup> polycarbonate roof and 30kgM<sup>2</sup> for a glass roof).

### U-Design

U-Design is a piece of design and configuration software that exclusively specifies UltraRoof380. As well as visualising and pricing, upon entry of the customer's postcode it checks the wind and snow loads at the exact location to ensure UltraRoof380 complies with Building Regulations.

**IT IS STRONGLY RECOMMENDED THAT THE ULTRAROOF380 INSTALLATION GUIDE IS READ AT THE SAME TIME AS THIS DOCUMENT.**



## HANDY CHECKLIST FOR: SELLING AND DESIGNING THE PERFECT ULTRAROOF 380

1. Choose the preferred roof shape (Georgian, Lean To, Victorian, Gable etc). Although the shape of most Victorian Conservatories can be replicated like for like, if the facets are uneven the Tudor Roof must be used. See pages 11 and 74.

---

2. Ask the customer precisely where they would prefer the glass in the roof. UltraRoofs full height rectangular glass panels are the most cost effective way to add glass, but are only available when connected to the ridge. Velux also can be used and located in most places on the roof. Refer to pages 8, 29 - 42.

---

3. Some box gutters may need internal beam support (See pages 34-35). If the customer wishes to change the box gutter types to avoid internal support this may restrict the placement of the glass. On some roofs there may be a trade off between internal support and glass placement. Read pages 47-55 and discuss this with the customer.

---

4. When a box beam is next to a host wall and a tapered gutter is used it does not require supporting (if under 4m clear span). All 265 boxgutters require supporting under the beam. Roof glazing choice must be considered when choosing boxgutter type. See pages 34-35 and 47-55.

---

5. The box beam has a maximum length of 7m but beams can be jointed. Where the joints are located due to the supports required see pages 6 and 67-72.

---

6. The beam cannot run unsupported over 4M. Avoid building bi-fold doors over 4M spans into the design to avoid the need for extra structural support. See pages 47-55.

---

7. Building Regulation compliance is required for SOLID roof conversions and new build extensions. See page 19.

---

8. Use the guide to explain how the soffit will look to the customer. See pages 26 and 62. Soffits over the window frames are available in 40mm and 151.5mm. Refer to page 63 and 67 to identify the right soffit on masonry. Please note, the 151.5mm soffit is the only option compatible with Loggia Super Insulated Columns.

---

10. Obtain the POSTCODE so that wind and snow loads can be checked. If you suspect these loads may be high refer to pages 43-46 to understand maximum potential roof sizes available.

---

11. There are many choices of finish to the UltraRoof380, much more than tiles. Ensure you have decisions from the homeowner on everything in the design. See pages 12-16.

---

12. Agree the roof pitch with the customer. Every roof must be pitched in full degrees (e.g. not 25.5°), duo pitches range from 15°- 40° and Lean To's start at 13°-40°. The only exception to this rule is the lowest Lean To possible which is 12.5°

---

13. Design the lighting layout with the customer. LED spotlights can be placed within the internal pelmet or added using a board at the ridge. Pendant lights can look particularly striking from the ridge of the new roof. See page 16.

Always consult Ultraframe if there is something you are uncertain about, please call Ultraframe's technical helpline on 01200 452 918 or visit [techsupport@ultraframe.co.uk](mailto:techsupport@ultraframe.co.uk)

4 STAGE SALES AND DESIGN PROCESS

**STEP 1 - LAYOUT - THINGS TO CONSIDER**

Any rectangular floor plan can be built, standard 3 & 5 bay victorians but NO P-shapes or T-shapes can currently be replaced. Valleys will soon be available. Stretch Victorian replacement roofs can be accommodated (see page 11).

The maximum length of UltraRoof380 beams are 7m but 2 can be joined together, however you will need a post or column where the beams join. Ensure the joint positioning is aligned with door or window frames Refer to page 67-68 for detailed information.

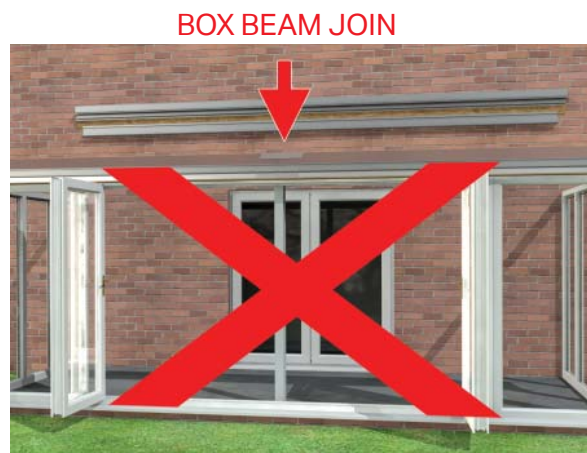
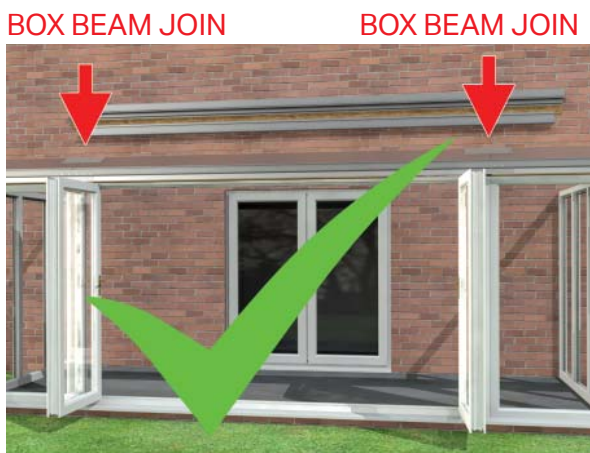

UltraRoof380 has 2 soffit depths 40mm and 151.5mm, see soffits shown on frames across. Discuss with the homeowner re depth of soffit required on brick work and frames. See page 63 and 64.

**STANDARD SOFFIT**

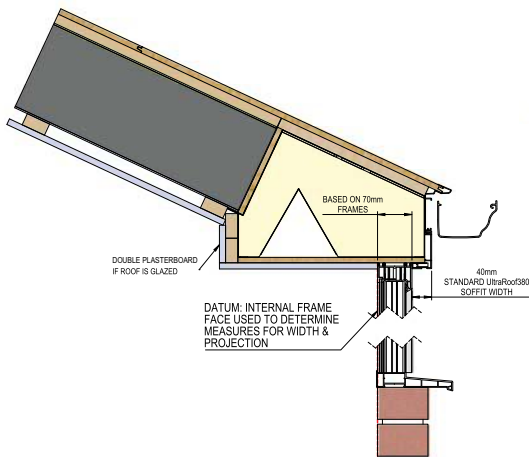

**EXTENDED SOFFIT**

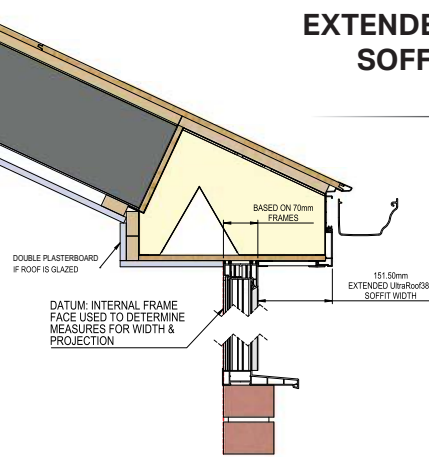

Loggia columns can easily be integrated with UltraRoof380. An extended soffit must be used with Loggia columns. See page 73.

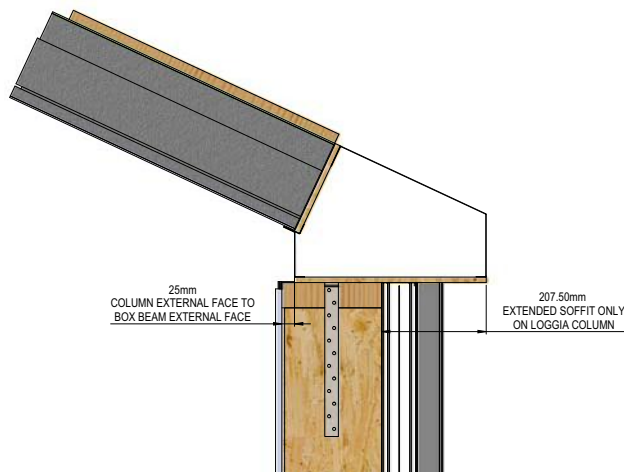

**STEP 1 - LAYOUT PLAN**

Show positioning of all walls (their heights), door openings, windows and expected soffit depths. Ensure the correct soffit is specified taking account whether the facets have frames, masonry or a combination of both.

**EXAMPLE BELOW:**  
Form to fill in overleaf



**ACCOUNT No.** (if known) ZTRA999

**Company Name** Home Improve

**Order Number** 129969

**Job Reference** Whittaker/Watson

**Company Contact** Mick Suter

**Telephone No.** \_\_\_\_\_

**Fax No.** \_\_\_\_\_

**Delivery Address** \_\_\_\_\_

**Delivery Date Req** \_\_\_\_\_

**Quotation Ref** (if previously quoted) 499081

**CRITICAL INFORMATION**

**Site Postcode** BB10 2BU

**Roof Pitch** 12.5°

**HOW TO PLACE AN ORDER FOR ULTRAROOF**

- Carefully read the UltraRoof380 guide.
- Sketch plan & elevations. (If necessary, attach photos of existing property. Indicate on drawings if any part of project is existing).
- Mark and caption the positions of all walls, brick piers, windows/doors, cut outs / intrusions.
- Mark the preferred positions of any a) roof windows or b) rectangular glazed panels.
- Upon placement of your UltraRoof380 order, an order confirmation is generated which must be signed and emailed back.

**NOTES:**  
Please see p2 of UltraRoof380 guide for list of what IS / IS NOT included

**PLEASE SKETCH YOUR PREFERRED DESIGN HERE - mark window, door & wall positions/ types. INDICATE ON DRAWINGS IF ANY PART OF THE PROJECT IS EXISTING**

**PLAN VIEW**

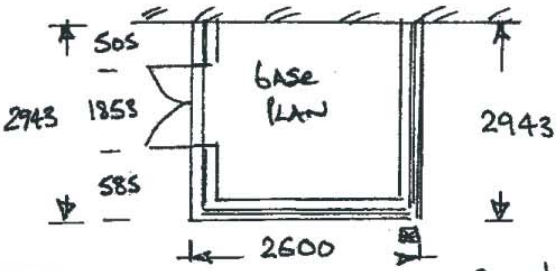

**FRONT ELEVATION**

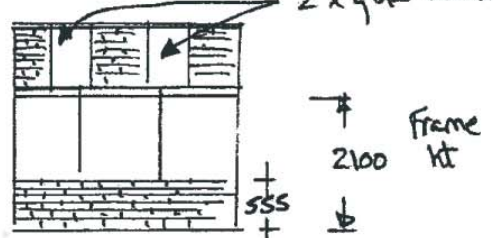

**LEFT ELEVATION**

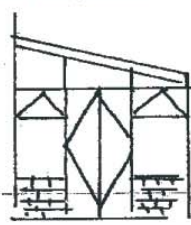

**RIGHT ELEVATION**

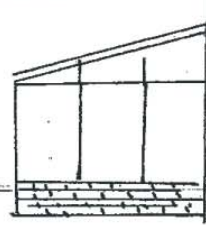

**DECIDE ON EAVES SET OUT** Tick box (a) or (b)

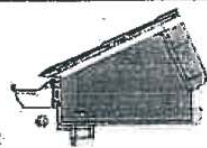
  
(a) Standard Soffit

  
(b) 150mm Soffit

**SPECIFICATION OPTIONS**

<p><b>TILE COLOUR</b></p> <input checked="" type="checkbox"/> Carbon grey <input type="checkbox"/> Harvest brown <input type="checkbox"/> Terra brick	<p><b>HIP AND RIDGE TYPE / FINISH</b></p> <input checked="" type="checkbox"/> Powder coated aluminium hip cap & ridge <input type="checkbox"/> Hip & ridge tile in same material as UltraTile <input type="checkbox"/> Hip / RIDGE COLOUR <input checked="" type="checkbox"/> Grey <input type="checkbox"/> Brown <input type="checkbox"/> Brick	<p><b>GLAZING OPTIONS</b>   <input type="checkbox"/> Rectangular glazed panels in positions above (mark plan)   <input type="checkbox"/> Unglazed for 24mm units   <input type="checkbox"/> Conservaglass 4S Blue   <input checked="" type="checkbox"/> Conservaglass 4S Neutral</p>
<p><b>ROOF VENTS (mark plan)</b></p> <input type="checkbox"/> Brass Mech <input type="checkbox"/> Chrome Mech <input type="checkbox"/> Electric Switch/Mech <input type="checkbox"/> Rain Sensor / Thermostat	<p><input type="checkbox"/> <b>GALLOWS BRACKET FOR BOX GUTTER</b> (if design needs one) QTY: _____</p>	
<p><input type="checkbox"/> <b>GABLE BOLSTER</b></p>	<p><b>GUTTER / DOWNPIPE &amp; SOFFIT COLOUR</b>   <input checked="" type="checkbox"/> White   <input type="checkbox"/> Black   <input type="checkbox"/> Brown   <input type="checkbox"/> Caramel</p>	
<p><b>VELUX ROOF WINDOWS (not supplied)</b> Please indicate positions above (mark plan).</p> <input type="checkbox"/> CK01 <input type="checkbox"/> CK02 <input type="checkbox"/> CK04 <input type="checkbox"/> CK06		



## 4 STAGE SALES AND DESIGN PROCESS

**STEP 2 - ROOF GLAZING**

Select from INTEGRATED ROOF PANELS or VELUX ROOF WINDOWS

**NOTE: If the roof design incorporates a boxgutter, the boxgutter type chosen will dictate your glazing option. Refer to pages 34-35.**

Full glass



No glass



Velux





4 STAGE SALES AND DESIGN PROCESS

**STEP 2 - ROOF GLAZING**

There are two box gutters available. Standard and tapered.

Some box gutters may need internal beam support (See pages 34-35). If the customer wishes to change the box gutter types to avoid internal support this may restrict the placement of the glass. On some roofs there may be a trade off between internal support and glass placement.

Limitations imposed by box gutter.

**STANDARD BOX GUTTER**

1. 265mm wide fabricated box gutter.
2. Must be used off fascia boards.
3. Can be used against vertical walls, if over 4m extra support will be required.

\* See pages 57-61 for intrusions and pages 47-55 for structural support options

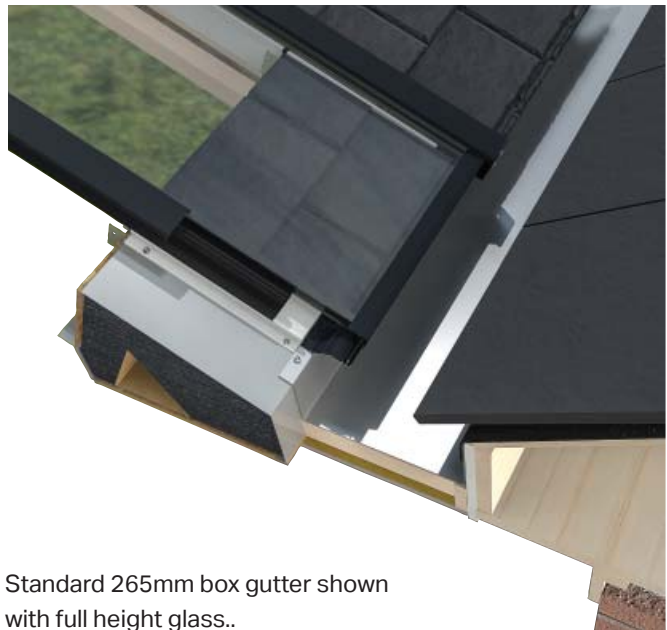

Standard 265mm box gutter shown with full height glass..

**TAPERED BOX GUTTER**

1. Used when box beam abuts host wall.
2. Used when roof SIP panes strike host wall.

\* No supplementary support required



Tapered box gutter shown with Velux.

## 4 STAGE SALES AND DESIGN PROCESS

**STEP 3 - ROOF STYLE - SHAPE**

Decide the roof shape best suited to the floor plan.



Lean-to



Georgian



Hip Back Georgian



Gable



3 bay Victorian



5 bay Victorian

### STEP 3 - ROOF STYLE - SHAPE

Tudor. See page 75 for details.

Existing Victorian shaped roofs can be replaced with a Georgian shape with a cantilever overhang which could include a lighting feature. This is particularly useful if the facets are uneven as UltraRoof380 can currently only accommodate even facets.



### Out of square.

UltraRoof380 can accommodate out of square existing buildings due to the wide nature of the beam. The soffit line will taper on both the inside and outside but the roof will remain square. The 151.5mm extended soffit MUST be used in this situation.

In extreme cases it might be better to recommend a re-build to make it square. See example below.

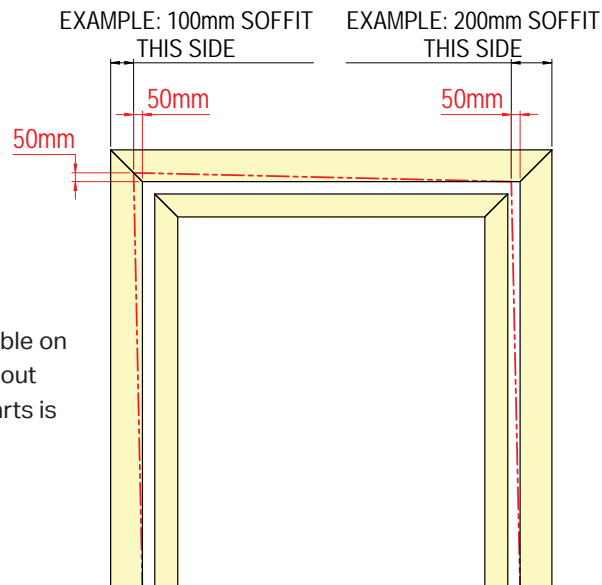

The deviation that is possible on standard 40mm soffit without on site modifications to parts is 10mm.



4 STAGE SALES AND DESIGN PROCESS

**STEP 3 - ROOF STYLE - RIDGE & HIP BAR**

Ridge hip tiles are available for UltraRoof380 but not recommended in certain situations due to the additional trimming and fitting required on site.



ULTRAROOF380 OPTIONS	RECOMMENDED aluminium hip and ridge capping	OPTIONAL Tiled Hips, aluminium Ridge capping	OPTIONAL hips and ridge tiles	Tile finishing details
Georgian solid or with Velux roof window	YES	YES	YES →	Fitted to timber batons and trimmed at intersection point on site. (Trimming approx 30 min)
Georgian with integrated rectangular glass	YES	YES	NOT RECOMMENDED →	Not traditional finish. Hip & Ridge tiles fit onto Hip & Ridge aluminium capping, tiles trimmed at intersection point on site. (Trimming approx 1 hour) Special end kit required. Check detail before ordering.
Victorian 3/5 bay solid or with Velux roof window	YES	NO	NOT RECOMMENDED →	Fitting/trimming of tiles at intersection point takes 2/4 hours on site. Aluminium capping option gives
Victorian 3/5 bay with integrated rectangular glass	YES	NO	NO →	No Solution Available



The most popular choice by far is aluminium top caps

- ✓ Increases profit
- ✓ Fast to fit
- ✓ Lower cost

## STEP 4 - FINISHING TOUCHES - COLOUR

The UltraTile polymer roofing system not only replicates the natural look of slate tiles but is easier to install and less expensive without incurring the extra structural cost needed to accommodate conventional slate roofing. The UltraTile polymer roofing system is also designed to outperform and be more cost-effective than any other synthetic slate tile replica system on the market.



- 12 tiles per panel – Fastest and easiest tile system to install!
- Most authentic looking tile on the market
- Much lower cost than fitting traditional slate tiles
- Lightweight co-polymer material - easy to install and transport
- Spacing and fixing guides making the tiles extremely quick to fit
- Fire resistance to ASTM standards
- Resistance to discolouration (U.V. rays)
- Perfect for replacement or new build projects
- Made from 100% recyclable material
- Virtually maintenance free
- Tiles laser cut in house for speedy installation

Available in 3 authentic colours to match 90% of UK housing stock



Carbon grey



Harvest Brown



Terra Brick

## 4 STAGE SALES AND DESIGN PROCESS

**STEP 4 - FINISHING TOUCHES - COLOUR**

Customers can choose the colour of guttering, fascia/barge board, downpipes, gables support cladding. See page 15 for the colour choices available.

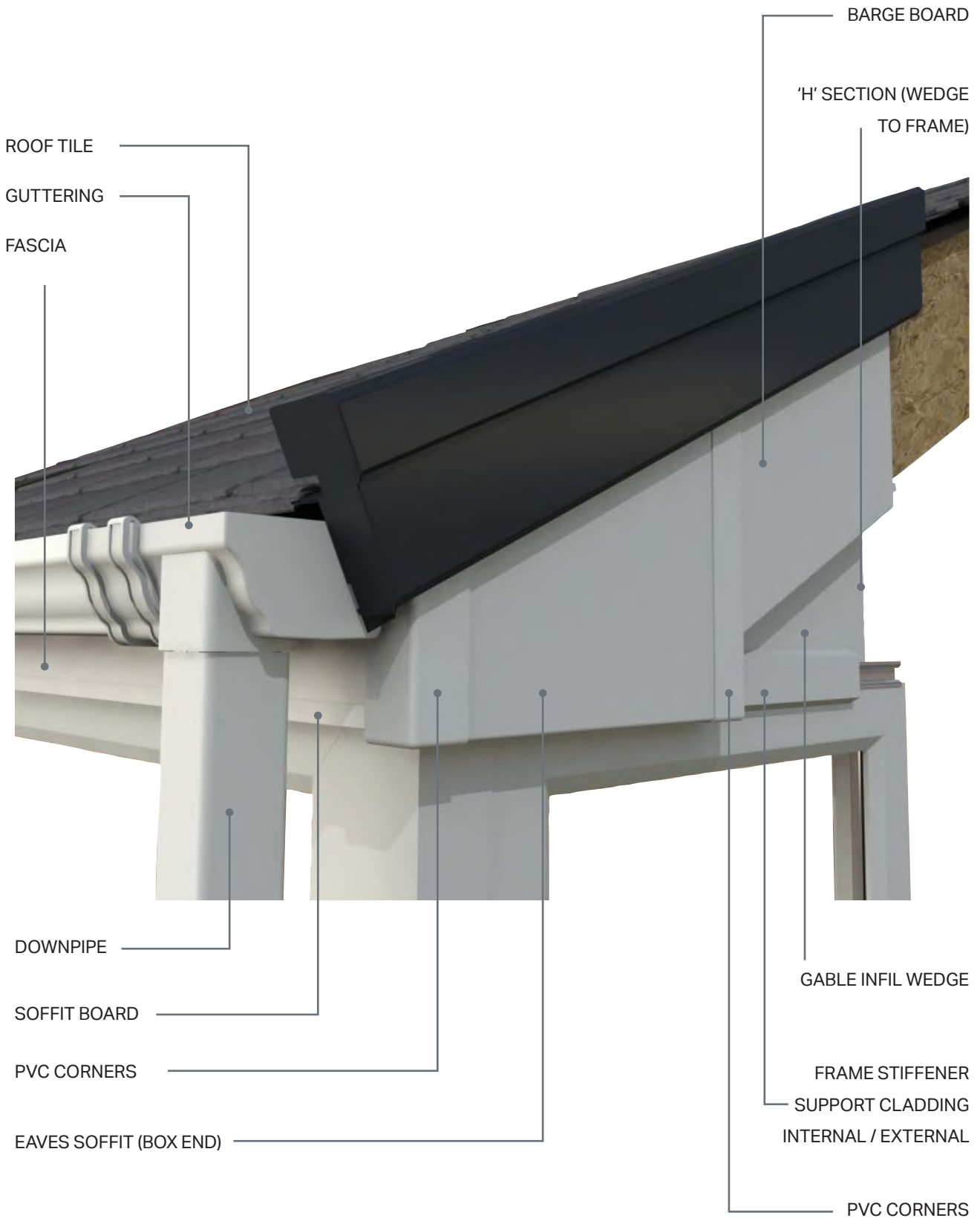



## 4 STAGE SALES AND DESIGN PROCESS

## STEP 4 - FINISHING TOUCHES - COLOUR

ULTRAROOF380 FOILED AND PAINTED PARTS											
PARTS	CODES	STOCK COLOURS						TILE SPECIFIC COLOURS			NOTE
		White	Light Oak	Mahogany	Rosewood	Black	Grey RAL7016	Carbon Grey	Harvest Brown RAIB025	Terra Brick Bespoke colour	
Fascia	NREB/3	y	y	y	y	y	n	n/a	n/a	n/a	
Downpipe		y	Caramac	Brown	Brown	y	n	n/a	n/a	n/a	
Frame stiffener	SSPC	y	y	y	y	n	n	n/a	n/a	n/a	
H Section	NRSE/1	y	y	map to Rosewood	y	y	y	n/a	n/a	n/a	
Barge board	NRBB/1	y	y	map to Rosewood	y	y	y	n/a	n/a	n/a	
Soffit board	NRSE/2	y	y	map to Rosewood	y	y	y	n/a	n/a	n/a	
Eaves soffit	NREB/4	y	y	y	y	y	y	n/a	n/a	n/a	
PVC corners	NRFCS, NRFC	y	y	map to Rosewood	y	y	y	n/a	n/a	n/a	
Tile	NRPA001	n/a	n/a	n/a	n/a	n/a	n/a	y	y	y	
Ridge/Hip tile	NRRH001	n/a	n/a	n/a	n/a	n/a	n/a	y	y	y	
Starter tile	NRPA002	n/a	n/a	n/a	n/a	n/a	n/a	y	y	y	
Modesty panel	NRPA001	n/a	n/a	n/a	n/a	n/a	n/a	y	n	n	
Gable cladding & end cap	NRGCA600MGR/1 NRDV001R/MGR NRDV001L/MGR	n	n	n	n	n	y	n	Wet paint	Bespoke wet paint	Inherits tile colour
Hip bar top cap & end caps	LMHC600MGR/1 LMEC004MGR NRHB002MGR	n	n	n	n	n	y	n	Wet paint	Bespoke wet paint	User defined, doesn't inherit tile colour
Ridge cap and radius ends	NRRI600MGR/1 NRGE001MGR NRVE003MGR	n	n	n	n	n	y	n	Wet paint	Bespoke wet paint	Same as hips
Glazing bar top & end caps around glass units	NRRA600MGR/1 NREC001MGR	n	n	n	n	n	y	n	Wet paint	Bespoke wet paint	Inherits tile colour
Glass support, end profile and tile starter support	NREB600MGR/5 UZLPEB600FMGR/5 NREB600MGR/1	n	n	n	n	n	y	n	n	n	n

## 4 STAGE SALES AND DESIGN PROCESS

**STEP 4 - FINISHING TOUCHES - PELMET LIGHTING**

Internal lighting can be installed with a standard or extended soffit. Surface mounted lighting can be used externally on the extended soffit. Internal light fittings must be fire rated. External lights must be waterproof, low voltage and suitable for external use.

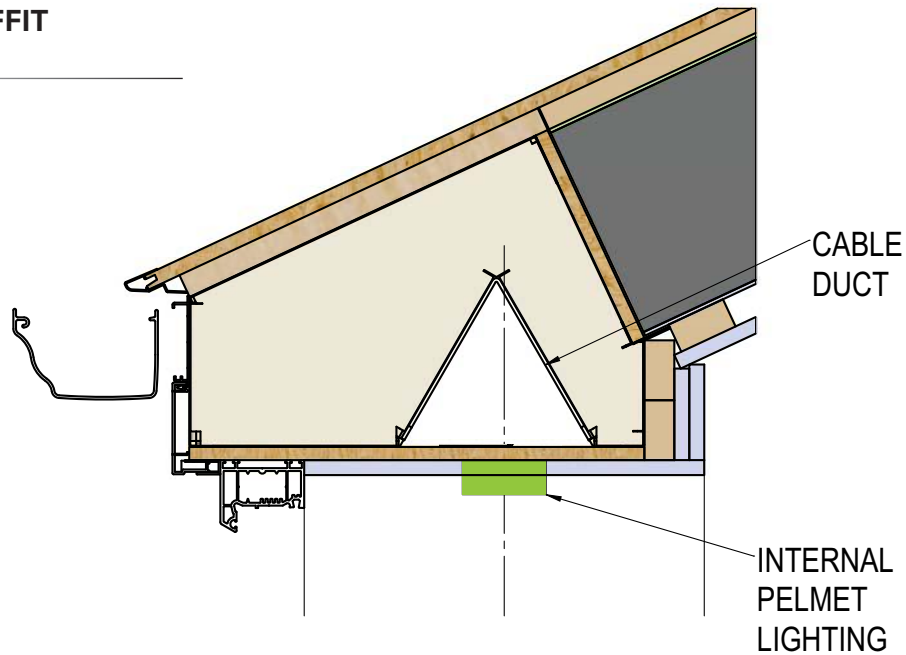
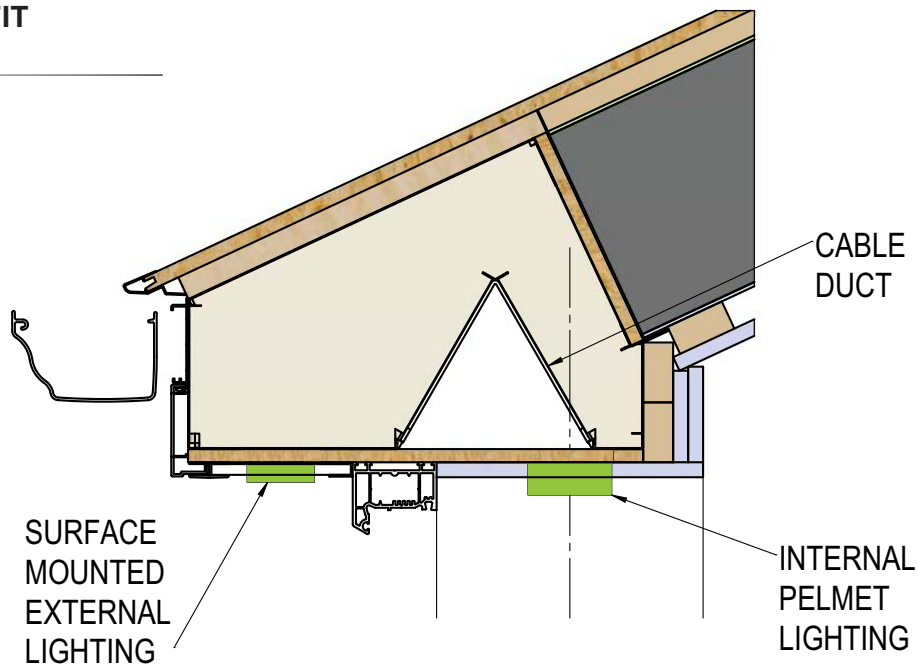
**STANDARD SOFFIT****EXTENDED SOFFIT**

\* IN THE EVENT OF ANY INSULATION BEADS FALLING FROM THE BEAM - REPAIR WITH BUILDING FOAM

## HANDY CHECKLIST FOR: SURVEYING ULTRAROOF 380

### GENERAL

- |   |  |
|---|--|
| <p><input type="checkbox"/> 1. Is planning permission or building regulation approval needed?<br/>If yes, who will apply?</p> <hr/> <p><input type="checkbox"/> 2. Is there sufficient access to the proposed building?<br/>Including height and width restrictions for delivery of material, concrete, frames, glass &amp; welded cills etc?</p> <hr/> <p><input type="checkbox"/> 3. Will construction involve crossing any public or neighbours path, garden, wall or hedge?</p> <hr/> <p><input type="checkbox"/> 4. Will you need a skip on site?</p> <hr/> <p><input type="checkbox"/> 5. Are there plants, bushes, trees, sheds, fish-ponds in the way?</p> <hr/> <p><input type="checkbox"/> 6. Are there any other visible obstructions on the ground?</p> <hr/> <p><input type="checkbox"/> 7. Is the house wall sufficiently out of plumb to require any allowance in the design of the roof? See page 23</p> <hr/> <p><input type="checkbox"/> 8. Are there any signs of settlement or hairline cracks in the house wall - have these been pointed out to the customer?</p> <hr/> <p><input type="checkbox"/> 9. Is there a soil vent pipe, RWP, extractor fan or gas flue in the way of the proposed roof?</p> <hr/> <p><input type="checkbox"/> 10. Are there any existing window or door openings to be moved, altered or bricked up?</p> <hr/> <p><input type="checkbox"/> 11. New openings to existing property will require new lintels which will require building regulation approval. See page 19 - building regulations.<br/>Fitting UltraRoof380 does not guarantee the removal of separating doors.</p> <hr/> <p><input type="checkbox"/> 12. Are there any existing window or door openings to be included within the newly proposed extension?</p> <hr/> <p><input type="checkbox"/> 13. Is there a height restriction above the proposed roof ie. a bedroom window?</p> <hr/> <p><input type="checkbox"/> 14. Ensure there is enough room above the ridge to lead flash?</p> | <p><input type="checkbox"/> 15. If installing to a bungalow fascia, lift the front row of tiles, Check that the roofing felt over the projecting eaves is in good condition or it will need to be replaced.</p> <hr/> <p><input type="checkbox"/> 16. Will the new extension roof fit below the bungalow soffit board?</p> <hr/> <p><input type="checkbox"/> 17. Will the new extension roof fit to the bungalow fascia board?</p> <hr/> <p><input type="checkbox"/> 18. Ensure there is fascia deep enough and in good enough condition?</p> <hr/> <p><input type="checkbox"/> 19. When installing a roof to the fascia is there enough room to re-fit the existing gutter?</p> <hr/> <p><input type="checkbox"/> 20. Will the UltraRoof380 overhang a boundary wall? With a standard soffit UltraRoof380 is 90mm wider than a standard conservatory roof on both sides and 205mm wider when the extended soffit is used.</p> <hr/> <p><input type="checkbox"/> 21. Has the right box gutter been specified? Refer to page 9</p> <hr/> <p><input type="checkbox"/> 22. Will the box beam need any structural support? Any box beam over 4m needs structural support (Gallows, Brick piers, timber stud work). Refer to pages 47-56.</p> <hr/> <p><input type="checkbox"/> 23. Will an extended soffit be needed? (e.g. with Loggia or brickwork Columns)</p> <hr/> <p><input type="checkbox"/> 24. Is there enough space on the house wall to allow for the box beam. It should not cut across openings on the host wall.</p> |
|---|--|

Always consult Ultraframe if there is something you are uncertain about, please call Ultraframe's technical helpline on 01200 452 918.



## HANDY CHECKLIST FOR: SURVEYING ULTRAROOF 380

### REPLACEMENT

1. Are there any "hairline cracks" within the existing base and walls to establish whether the existing structure is sound.
- 
2. Are the existing window frames in good condition or is there for example evidence of cracking welds within the frames.
- 
3. What are the internal and external frame sizes and relevant apertures?  
These must all be measured to ensure the desired overhang is achieved.
- 
4. Will existing cavity trays and flashing need to be moved, because UltraRoof380 sits higher on the slope? 53mm higher with a standard soffit and 100mm higher with an extended soffit.

### NEW BUILD

1. Are there any existing structures to demolish?
- 
2. Is there an existing patio or path to be removed?
- 
3. Is there an existing retaining wall - will this need re-constructing?
- 
4. Are there any projecting bell casts, soldier courses, key stones in the way?
- 
5. Are there any TV, satellite or telephone cables in the way?
- 
6. Are there air bricks or head ventilators in the existing extension?
- 
7. What is the existing external wall finish - Facing brick, stone, render or pebbledash to match to?
- 
8. If facing brick, is a cavity tray required?
- 
9. Will you need to install a vertical damp proof course where the side frames abut the house/bungalow wall?
- 
10. Are there any existing underground drainage pipes to be moved or build over?

### NEW BUILD

11. Is there an existing manhole to be moved or raised to the new extension floor level then sealed with an airtight cover?
- 
12. Are there any pipes or cables to be catered for in the proposed build?
- 
13. Will the difference in house floor level and the proposed new extension floor level require steps?
- 
14. Will the difference between the proposed new extension floor level and the outside ground floor level need a landing, steps and handrail?
- 
15. Is a dwarf wall required - what height?
- 
16. Are there squint bricks or stone quoins required or will you cut and bond bricks?
- 
17. Are there any new openings required in the proposed basework for doors?
- 
18. Is the site sloping away requiring extra height to the basework?
- 
19. Is the site sloping towards the basework requiring excavation?
- 
20. Will a retaining wall be needed?
- 
21. Is a new path or patio area required?
- 
22. Check coursing and spacing of brickwork against existing - ie Imperial or Metric
- 
23. Is the new extension rainwater to discharge into an existing gully or is a new gully required?
- 
24. Is there a sufficient number of rainwater outlets for the size of roof?
- 
25. Is there an existing gully to move?
- 
26. Has all the detail been discussed and agreed with the customer

## BUILDING REGULATIONS

Building regulations for replacement conservatory roofs are ambiguous, however we recommend that retailers apply for building regulation approval because the lack of a completion certificate can become a costly issue when the property is sold.

UltraRoof380 meets building regulation requirements. To ensure the design is fit for purpose, please provide the postcode so that wind and snow are applied correctly to the design. In addition to the quotation Ultraframe can provide a thermal report to enable SAP calculations to support the building regulation application.

### ENGLAND & WALES - REPLACEMENT ROOFS

Building regulations for replacement roof projects can be applied for EITHER through the Local Authority Building Control Department OR through a private sector Approved Building Control Inspector.

The design details for UltraRoof380 has been registered with JHAI, an Approved Building Control Inspector who have audited the UltraRoof380 manufacturing process. JHAI's inspectors provide a consistent and informed service when applications are made to them, typically with only one inspection visit arranged directly with the householder. For more details visit [www.UR380info.com](http://www.UR380info.com)

### ENGLAND & WALES - NEW BUILDS

Building regulations for new build projects can be applied for EITHER through the Local Authority Building Control Department OR through a private sector Approved Building Control Inspector.

JHAI offer building control service for new build projects, with up to six visits to site if required depending on the complexity of the project. Please visit [www.UR380info.com](http://www.UR380info.com) to download details of JHAI's costs and service.

### SCOTLAND

A building warrant is required for all roof replacement and extensions in Scotland. An SER (Structural Engineers Report) is typically required as part of the warrant application. Please consult Ultraframe if you need advice on structural engineers who have experience with UltraRoof380.

#### MAKE AN ENQUIRY

- Email enquiry/quote form to [quotes@ultraframe.co.uk](mailto:quotes@ultraframe.co.uk)
- Always include site postcode

#### RECEIVE A QUOTE

- Structural Design Report
- Thermal Report
- Quote

#### OBTAIN SER REPORT

- Retailer commissions a Structural Engineer to provide SER for complete structure
- Send Ultraframe Structural Design Report to Structural Engineer

#### SAP CALCULATION

- Retailer commissions Engineer to provide SAP calculations
- Send Ultraframe Thermal Report to SAP Engineer

#### WARRANT APPLICATION

- Apply to local Authority Building Control for approval
- Send Warrant Application with SER and SAP Calculation

## ASSESSING THE EXISTING CONSERVATORY

Changing the roof on a previously exempt conservatory from glazing to solid panels means that you have changed the status of the structure.

The new roof is seen as an improvement and MUST comply with parts of the Building Regulations (this assumes the doors separating the house and conservatory are retained). There is a caveat – the replacement roof should not make the condition of the existing structure worse – this relates to the ability of the existing side frames and foundations to carry the additional loads imposed by the solid roof. It is necessary to undertake some structural checks that MAY lead to additional site works.

Adequate support from the existing structure is required in three main areas by:

1. Window frames.
2. Mullions/corner posts.
3. Foundations.

### PVC WINDOW FRAMES

The primary fixing method of the roof is at the house wall and through the head of the window frames and into the beam. At the corners fixing is made through the existing frames into the OSB corner sheaves (which are supplied) and into the beam. When fitting UltraRoof380 onto the existing frames, then the side frames may need de-glazing to allow fixing of box eaves beam. Use bay pole fixings at 450 centres and no more than 200mm from each eaves end / corner.



### CORNER POSTS

Unreinforced PVC Frames. If at survey stage there is no reinforcement within the PVC frames it may be necessary to replace the corner posts. The dead load of UltraRoof380 is 38Kg/m<sup>2</sup> plus the snow load which as a minimum is typically 60kg/m<sup>2</sup>. On a 5m x 5m Georgian roof for example, the load is 2803Kg which translates to a maximum loading at each corner of 7kN.

Using the table to the right it can be seen that an aluminium corner post of 50mm square hollow section with a 2mm wall will be adequate - generally corner posts will be larger than this. At survey stage it may be difficult to confirm the presence of the aluminium inside the PVC sleeve until the roof is removed. Assuming new frames are not being installed, it may be advisable to send with the fitters some spare corner posts to swap with the existing.

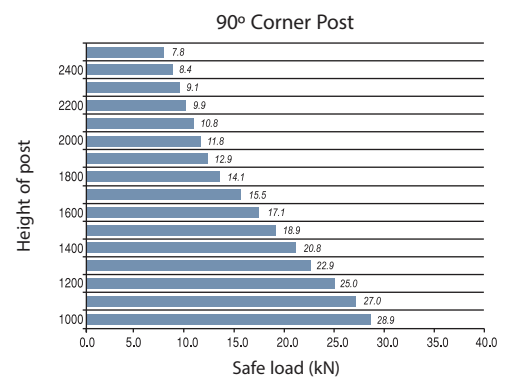
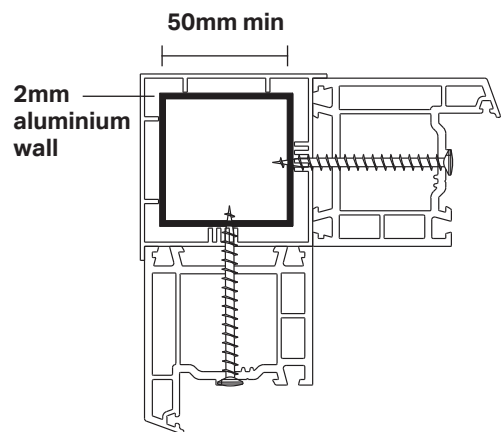



## ASSESSING THE EXISTING CONSERVATORY - GUIDELINES

### MULLIONS

An aluminium mullion performs a number of functions, namely;

- acting as a wind post to prevent deflection of the frames by wind pressure
- to support the roof's eaves beam
- to assist with the connection of the side frames.

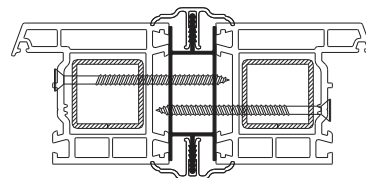

Mullion as a wind post:- the size of the mullion depends on the height of the frame. With full height frames (2100mm) the mullion needs to be the full front to back depth of the window frame and at least 20mm wide.

Adding mullions to existing frames is not really viable – this option should be considered if the consumer has requested new frames/doors. Should the PVC frames be replaced, the insertion of suitable mullions can obviate the need for reinforcement in the frames (as far as structural reasons are concerned) – when using mullions, always place a 20mm washer behind the head of the screw to spread fixing loads.

### FOUNDATIONS

As everyone knows and appreciates, foundation design greatly depends on local ground conditions and advice should be sought from local LABC or an Approved Inspector like Ultraframe's partner jhai. However there are some rules which are absolute and therefore if the proposed conservatory falls outside this it may be necessary to underpin the existing or remove the existing base and start again. Take up the old foundations if;

- There is an inadequate depth of foundation. The strip foundation **MUST** be a minimum of 450mm and the concrete strip a minimum of 150mm thick.
- There is visible movement between the house wall and the conservatory dwarf wall or cracks in the dwarf wall - this is a clear indication the foundations are not adequate and also require remedial work.

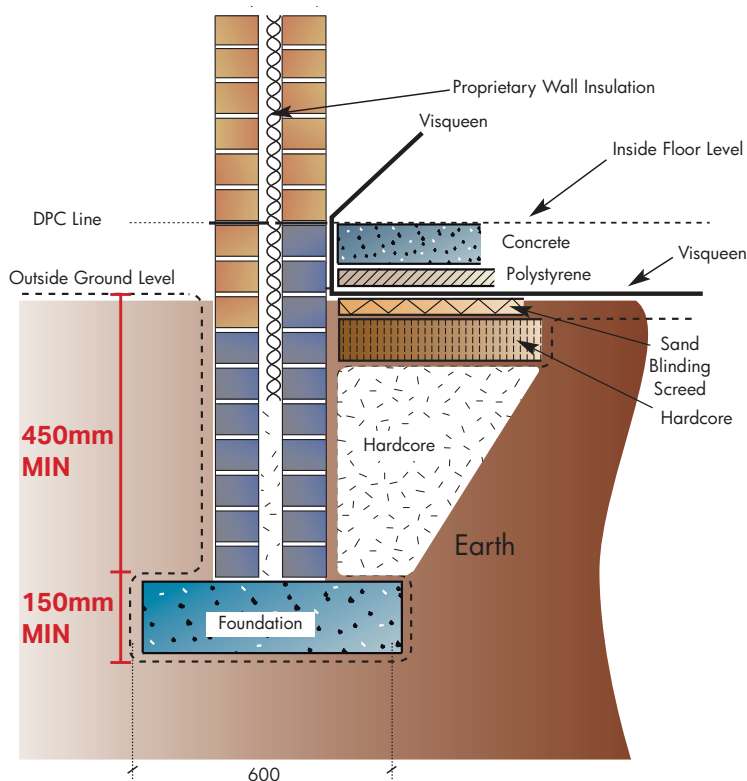

Remediation work (mini piling etc.) can be undertaken cost effectively – Ultraframe recommends **QUICKBASE 0845 644 0000** if you wish to pursue this option.

**IF IN DOUBT ABOUT STRUCTURAL COMPLIANCE, PLEASE CONSULT LABC, Jhai OR A STRUCTURAL ENGINEER.**

## ULTRAROOF380 SURVEYING GUIDELINES

UltraRoof380, light weight solid roofing differs from Ultraframe Classic conservatory roofing in that, it offers a traditional overhanging soffit area beyond the external frame face. Initial site survey is no different in that great care must be taken in examining the existing host wall for being flat (ie: bulges or bowing from left to right) and vertically plumb (ie: leaning forwards or backwards). If any of the above issues are detected then this must be allowed for in your final sizes.

### ULTRAROOF380 IS WORKED FROM INTERNAL FRAME SIZES.

If replacing a conservatory roof on **60mm frames** with **Standard soffit**, the soffit overhang **increases to 50mm**.  
If installing on **100mm frames**, the Standard soffit overhang would **reduce to 10mm**.



INTERNAL FRAMES	OVERHANG IS SET	WHEN BOX EAVES BEAM SAT ON
STANDARD SOFFIT	40mm	70mm frames
EXTENDED SOFFIT	151.5mm	70mm frames

### ULTRAROOF380 INFORMATION

- 1 UltraRoof380 must be made square, with EQUAL angles (i.e: 90, 135 or 150 degree angles), EQUAL facet sizes and EQUAL pitch - Out of square can be accommodated or Tudor used. See pages 75-76.
- 2 Lean-To's with hipped end(s) must have SAME pitch front and side(s).
- 3 Every roof must be pitched in full degrees (e.g. not 25.5°), duo pitches range from 15°- 40° and Lean-To's start at 12.5°, otherwise 13-40 in one degree increments available in full degree increments.
- 4 On replacement roof only jobs existing internal frame angles may vary. This will result in varying internal/external soffit depth variations being visible. If extreme, replacing the frames would be recommended. If existing basework/ brickwork angles are out, the fitting of a deeper external cill may hide discrepancies.
- 5 Externally, UltraRoof380 with "Standard soffit" is 180mm (90mm each side) wider than Classic roof. Greater care is needed when working close to the boundary line. UltraRoof380, coincidentally, is the same width as Classic roof with Cornice .i.e: 242mm from internal frame to outer edge of gutter.
- 6 Externally, Ultrarroof380 with "Standard soffit" sits 53mm higher on slope/pitch than Classic roof. This should not affect an existing lead flashing line if going to be re-used.
- 7 Externally, UltraRoof380 overall roof height (stated on roof confirmation) is measured from underside of box eaves beam (head of frame, unless packed off) to top of external ridge top capping. Allow for standard ridge flashing detail above this.
- 8 Externally, if fitting "Extended soffit" the roof sits 100mm higher on slope/pitch than Classic. This could interfere with existing flashing detail. Critically more important if a cavity tray is installed. Therefore, if cavity trays are installed, standard soffit overhang would be better suited.
- 9 Internally, using "Standard soffit" detail: The box eaves beam (when plastered) stands 321.5mm in from internal frame. ENSURE this does not cut across an internal patio door/window opening on the rear host wall. Using "Extended soffit" which stands only 210mm in from internal frame may help in this situation. Reducing the opening width and replacing with narrower doors may be an alternative solution. See page 26.
- 10 Internally, each box beam contains a built-in cabling channel, the centre of which is set 123mm in from the internal face of the steel box beam. See page 26.

## EXAMINING THE HOST WALL

This information applies to both replacement and new build projects. Please read this guide before commencing your survey.

### Check the House Wall

The box beam is large and should not be cut on site. Tiles are pre-cut to minimise work on site. As a result adjustments in size due to variations in the house wall are best made at survey stage.

Please check the house wall to establish whether it is plumb. Adjusting the projection dimension before manufacture will ensure your design will fit. Please advise your installers that you have made this adjustment to avoid confusion on site.

### New Build.

If the house wall leans forward: when the UltraRoof380 half ridge (shown) butts to the house wall the whole conservatory will be pushed forward of the basework, resulting in excessive overhang at the front. You would benefit by reducing the projection in this case to . See Diagram A.

If the house wall leans backwards: then the roof projection dimension should be taken from the top of the dwarf wall and a suitable packer will need to be inserted between the end of the ridge and house wall when installing. See diagram B.



Diagram A

Diagram B

### Replacement Roofs.

If the roof is being replaced adjustments for out of plumb dimensions should be taken at eaves level, reducing the projection if the wall leans forward or adding to the projection if the wall leans back.

## CALCULATING THE ROOF SIZE

### What is the Supporting Structure?

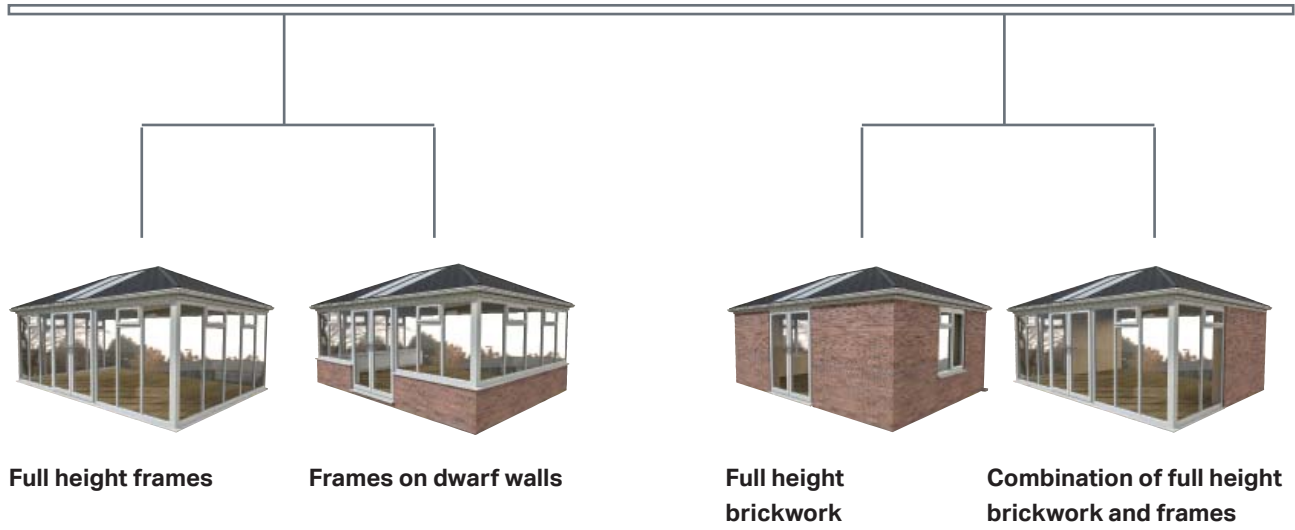

Use internal frame measurement to order

Use internal frame measurement to order OR  
Use finished roof measurement to order (fascia to fascia)

### Which soffit type do you want?

### Which brick option do you want?

- A STANDARD**  
Soffit Widths = 40mm
  - \*B EXTENDED**  
Soffit Widths = 151.5mm
- \*Compatible with Loggia Columns

- \*1** Soffit Widths = **BRICK 94mm | FRAMES 126.5mm**
  - 2** Soffit Widths = **BRICK -190mm | FRAMES 40mm**
  - \*3** Soffit Widths = **BRICK 7.5mm | FRAMES 40mm**
  - 4** Soffit Widths = **BRICK 40mm | FRAMES 72.5mm**
- \*Compatible with Loggia Columns

FOR INFORMATION ABOUT HOW THE SOFFITS WILL SIT OVER WINDOW FRAMES SEE PAGE 61

FOR ADDITIONAL INFORMATION ON OPTIONS FOR HOW THE SOFFIT WILL SIT ON BRICKWORK SEE PAGES 63-67.



## SPECIFIERS

### – USEFUL POINTS TO REMEMBER WHEN ORDERING ULTRAROOF 380

1. A Building Regulation application form must always be submitted to the relevant Local Authority or private sector building control.

---

2. Postcodes should always be included with your order so that the structural design guide within the software will ensure the snow and wind loads are correct.

---

3. With a standard soffit UltraRoof380 is 90mm wider than a standard conservatory roof on both sides and 205mm wider when the extended soffit is used. Include all WALL heights and distances to boundary lines in floor plans and elevations.

---

4. UltraRoof380's aluminium ridge and hips caps are generally preferred vs replica tile ridge caps as they are considered to look better and are fitted much faster. Both options are available, see page 12 for restrictions.

---

5. All new window frames and cills should be fully reinforced to support UltraRoof380. A maximum frame length of 2.5m is allowed before structural couplings are required.

---

6. UltraRoof380's unique full height glass panels are the most cost effective way to install glazed panels and are consumer preferred due to their size. There are however some limitations to the glazing options offered. See pages 29 and 35.
  - Rectangular glass units can NOT be positioned on roof slope down to tapered box gutter.
  - 550mm wide Velux roof windows only. Can be installed to tapered or 265mm box gutter.
  - Integrated glazing. Only rectangular glass units up to 1,000mm wide at 90° to the ridge are permitted.

---

7. The UltraRoof380 box beam requires structural support in certain situations e.g. over 4M spans and when a 265mm box gutter is used. The structural support options offer a design choice for homeowners. Ensure that the options have been agreed with the homeowner in advance. Refer to pages 47-56.

---

8. During the initial stages of installation the box beam will need to be supported. Ensure timber support props or acro props will be available on site, refer to installation guide.

---

9. There are two box gutter options; standard 265mm or tapered. Tapered box gutters can only be used when box beam or roof panels directly abut host wall. Refer to pages 9 and 34-35..

---

10. UltraRoof380 comes in three shades of authentic tiles and you can order a range of colours for Fascia board, Barge board, Gable infill & Guttering etc. See pages 13-15 for options

---

11. Several items are not supplied by Ultraframe as they are easier and cheaper to source locally. These are:-
  - Velux roof windows and EDL flashing kits (the roof arrives prepared for Velux)
  - Anchor or Masonry fixing bolts to host wall
  - Internal 25mm x 50mm timber plastering battens.
  - 12.5 foiled backed plaster board and skimming beads.
  - LED (fire resistant) lighting.
  - Structural support

Always consult Ultraframe if there is something you are uncertain about, please call Ultraframe's technical helpline on 01200 452918

## PRODUCT ASSEMBLIES

SPECIFYING

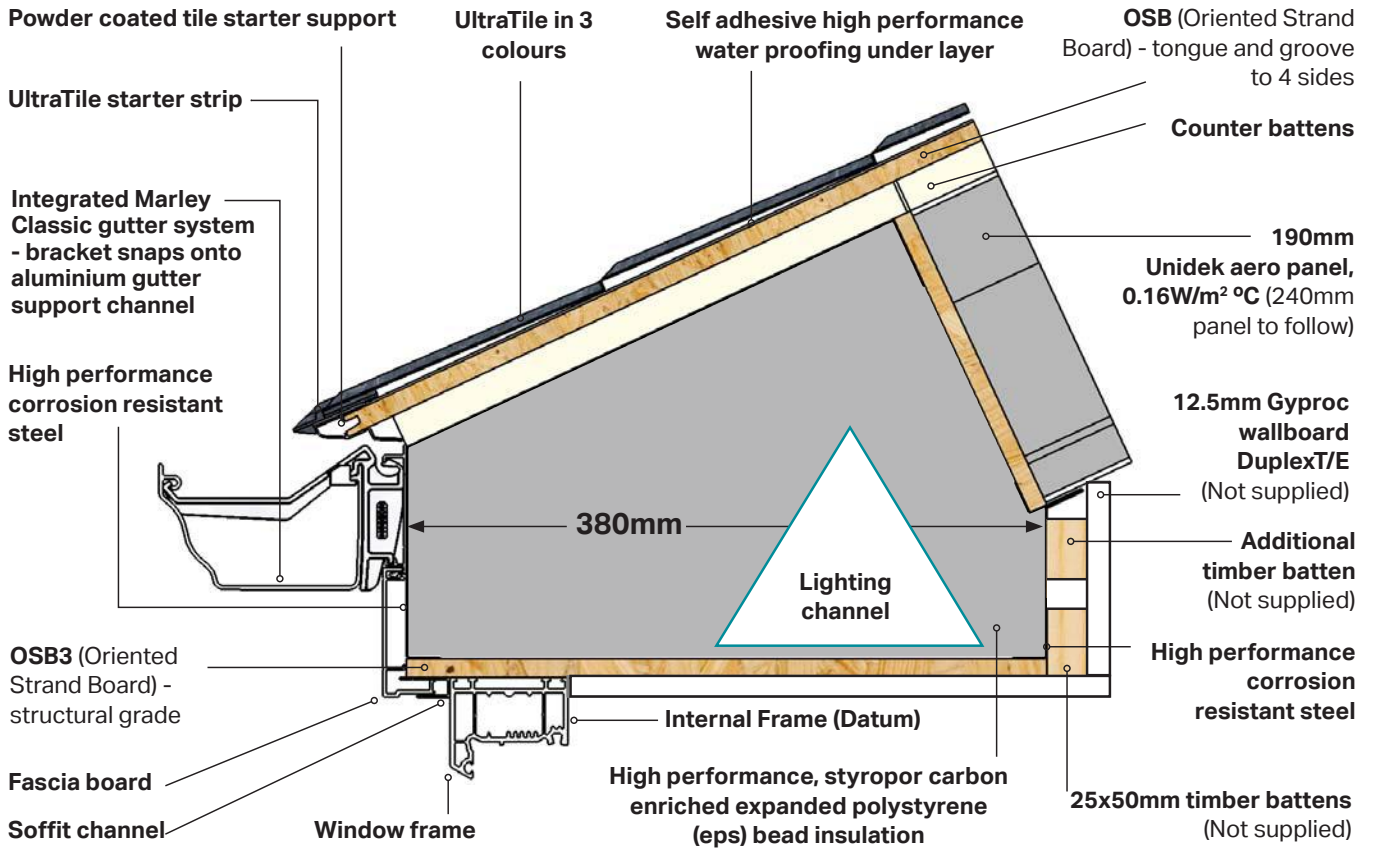

### Standard Soffit

NOT SUITABLE FOR LOGGIA COLUMNS

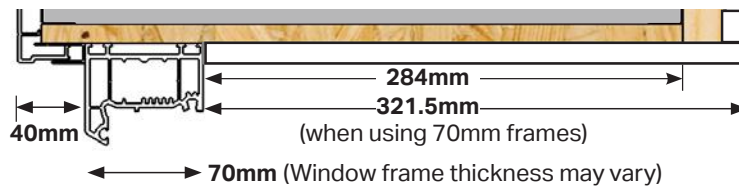

**EACH BEAM INCORPORATES A BUILT - IN CABLING CHANNEL FOR INTERNAL SOFFIT LIGHTING. THE CENTRE OF CHANNEL IS SET 123MM IN FROM THE INTERNAL FACE OF THE STEEL BOX BEAM, 161MM FROM PLASTERBOARD LINE.**

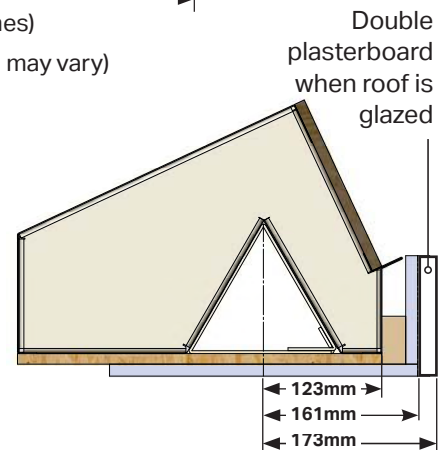

### Extended Soffit

MUST BE USED ABOVE LOGGIA COLUMNS

Alternative (only option if sat on Loggia columns).

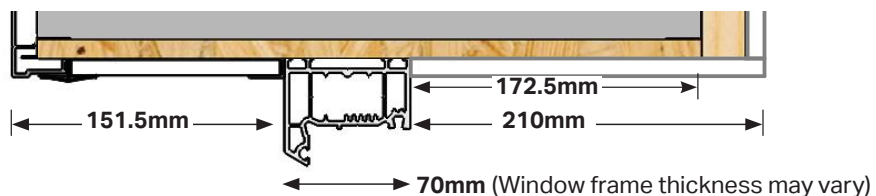

# PRODUCT ASSEMBLIES

Beam glass



Beam solid



Ridge solid solid

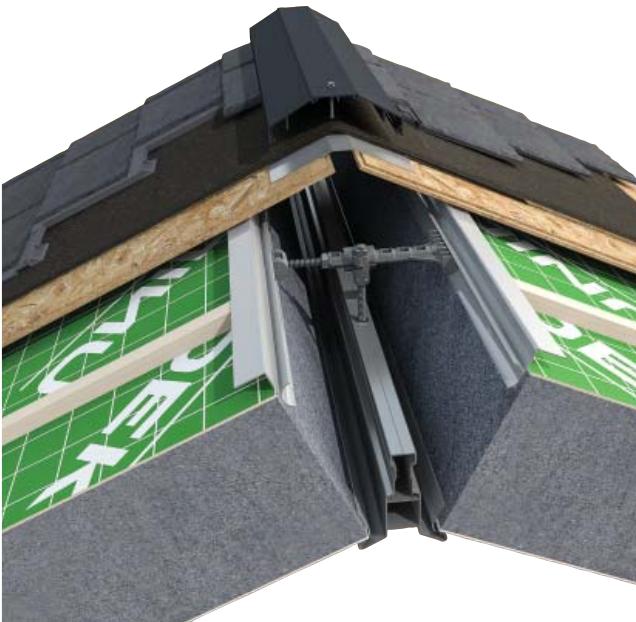

Ridge solid glass

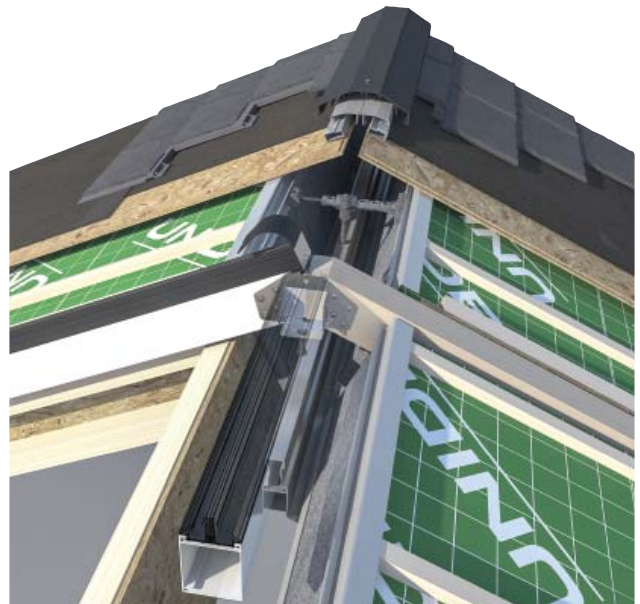

Ridge glass glass

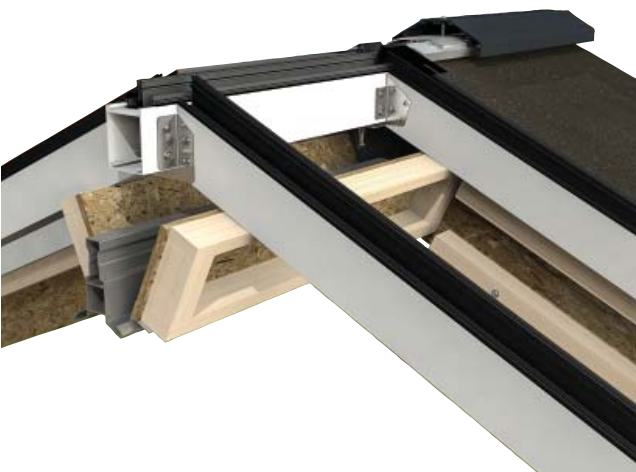

265 boxgutter solid

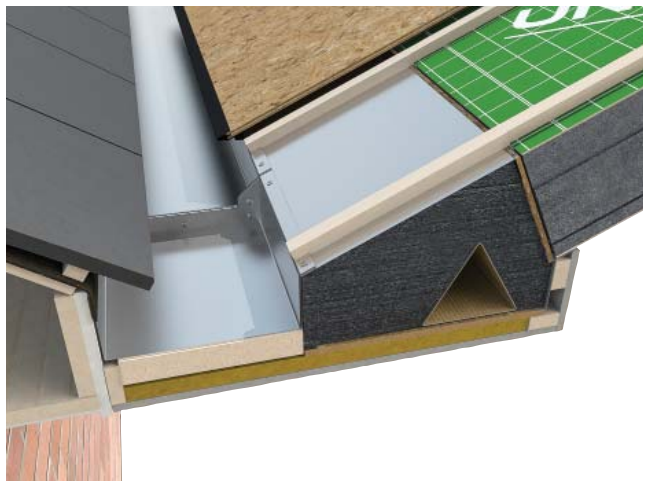



# PRODUCT ASSEMBLIES

265 Boxgutter glass

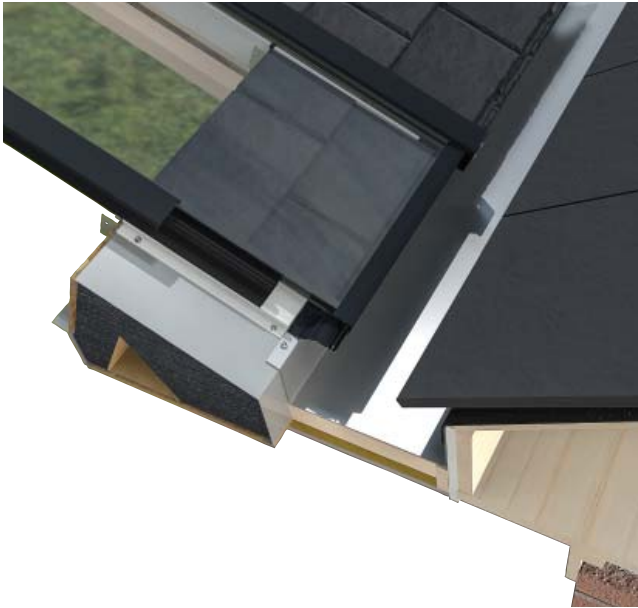

Tapered boxgutter



Half ridge glass



Half ridge solid



Bars



Gable extended soffit overhanging side frames



Lean-to only



# ROOF GLAZING

Select from INTEGRATED ROOF PANELS or VELUX ROOF WINDOWS

**NOTE: If the roof design incorporates a boxgutter, the boxgutter type chosen will dictate your glazing option. See options and instances on p34-35.**

## INTEGRATED GLAZED PANEL POSITIONING

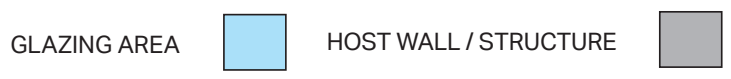

### Georgian and Victorian

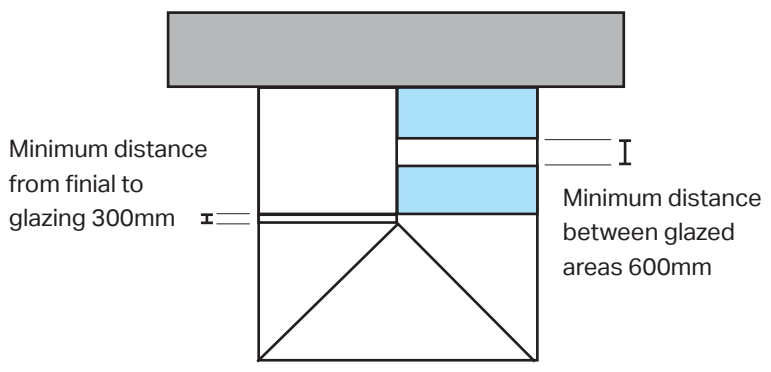

### Lean-to

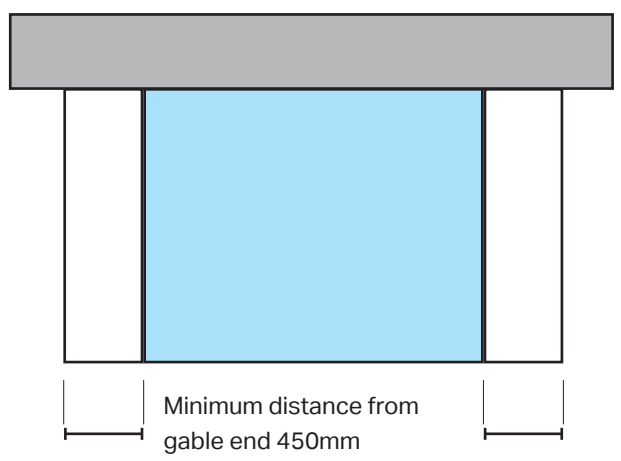

### Gable

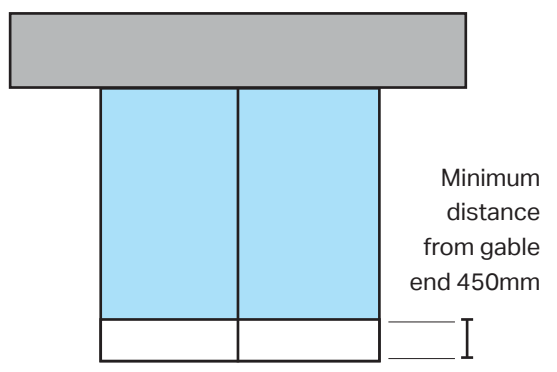

Glazing can be fitted immediately adjacent to the host wall or MUST be at least 450mm away from the host wall.

- Glazing area
- bars must be a minimum of 300mm centres
  - are spaced at a max 1000mm centres
  - multiple glass panels in series is possible. e.g. 1800mm glazed area in 3x 600mm or 2 x 900mm.

## INTEGRATED GLAZING RULES

### WHEN CAN YOU HAVE GLAZING?

GLAZING PANEL  
MAX 1000mm



up to an area of 2.4m<sup>2</sup>

One of UltraRoof380's features is the ability to have fully glazed panels that span right from the ridge to the edge of the roof, allowing great amounts of light to enter a room. These glass panels can be arranged in all manner of ways and configurations to give the desired result for design of the roof. The following outlines the options for glazing in the different styles UltraRoof380.

#### Solid panels at host wall.

#### Glass panels adjacent.

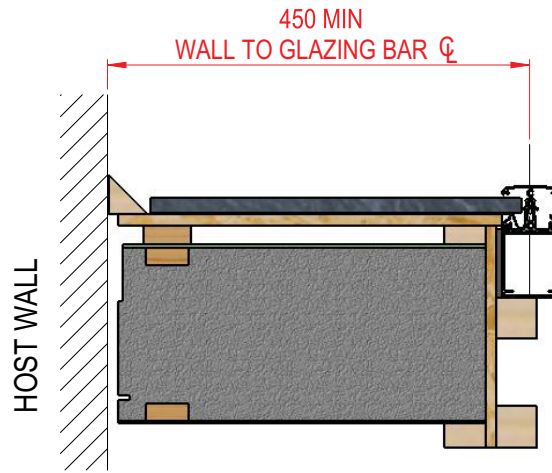
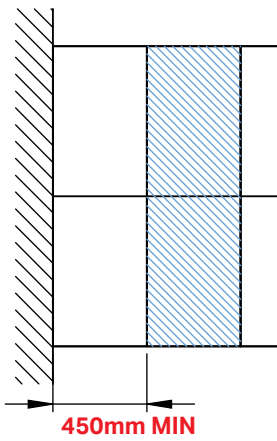

#### Glass panels at host wall.

#### Glass panels adjacent.

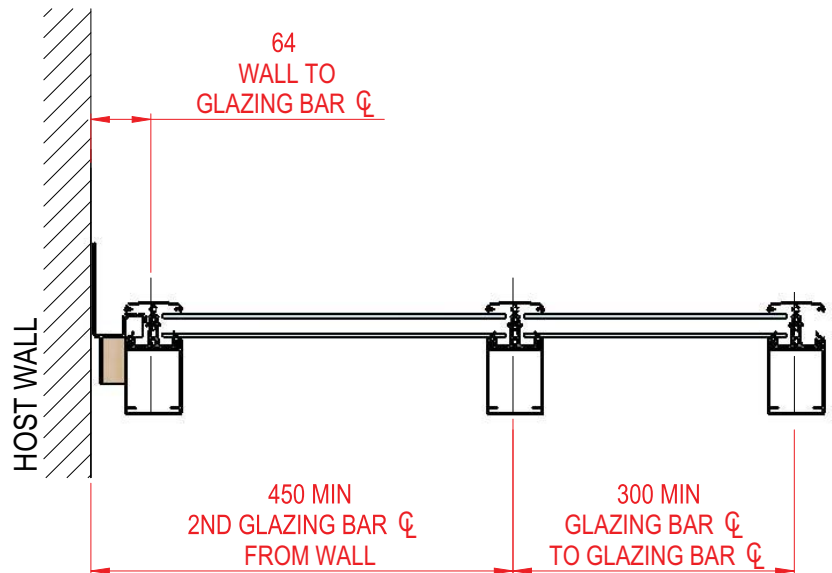
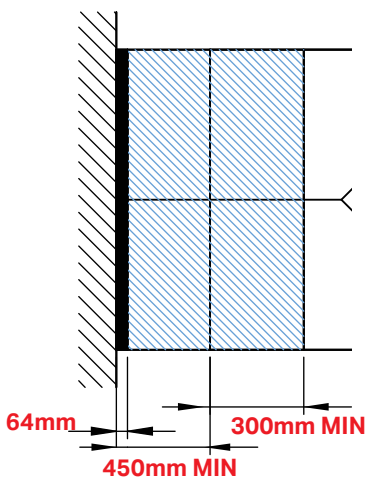

# INTEGRATED GLAZING RULES

Glass panels at host wall one side.  
Solid panel at host wall opposite.

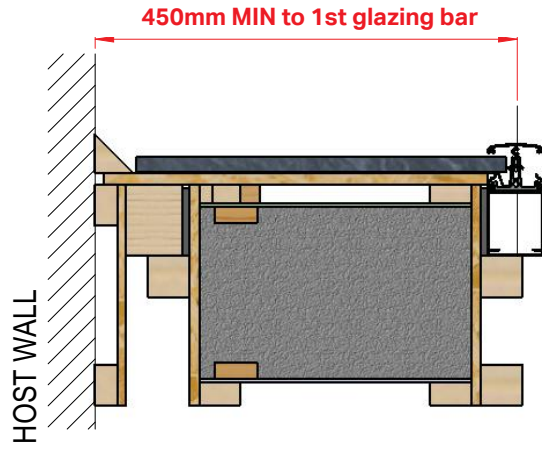
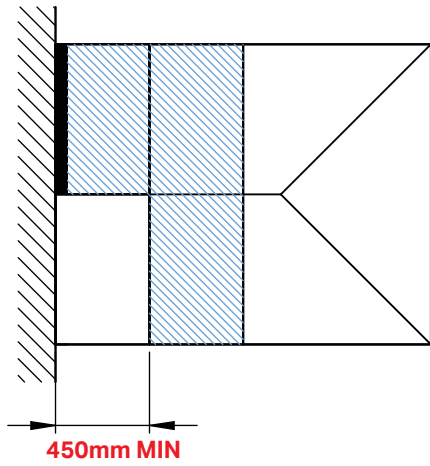

Glass panel one side.  
Solid panel opposite.

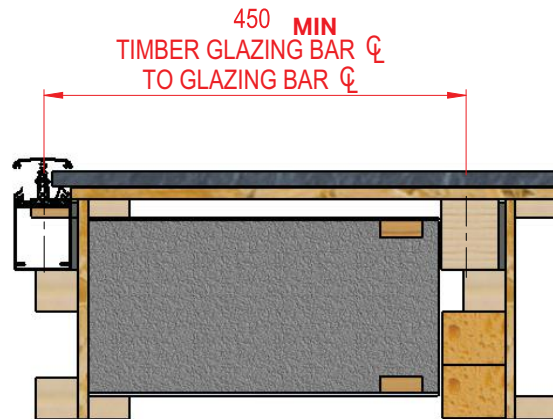
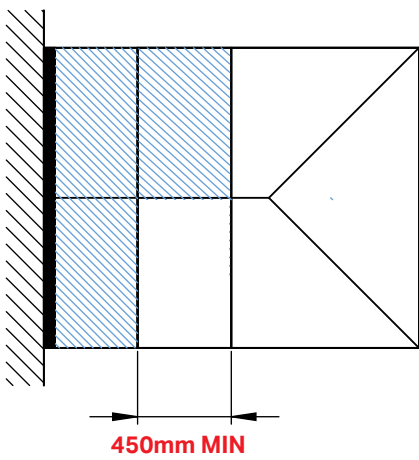

Glass from finial point

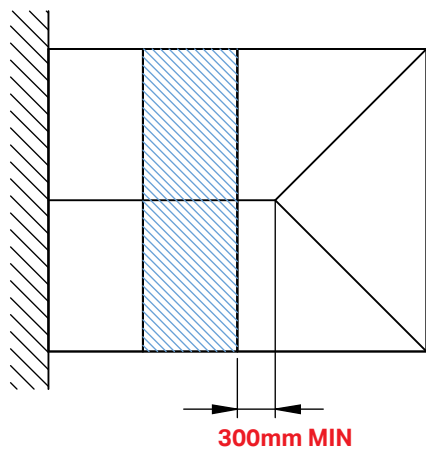

300mm MIN glazing bar to finial point

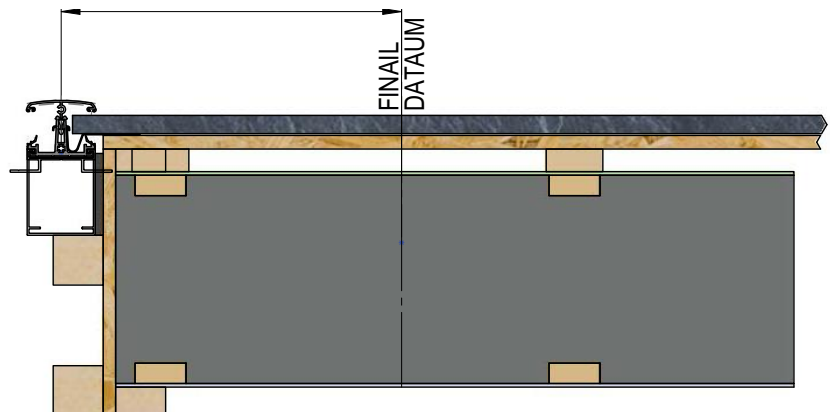

## INTEGRATED GLAZING RULES

INTERNAL  
FRAME LINE



GLAZING PANEL  
MAX 1000mm

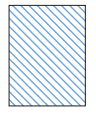

### Solid panel between glass panels

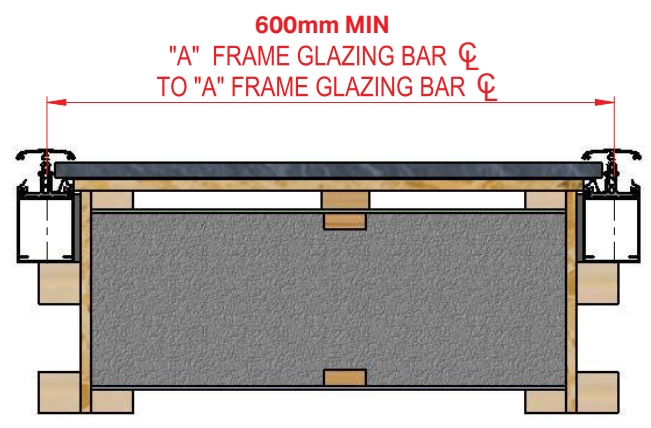
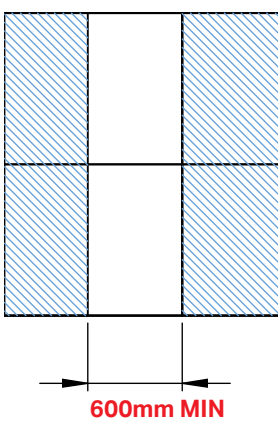

### Glass from gable end and lean to gable ends

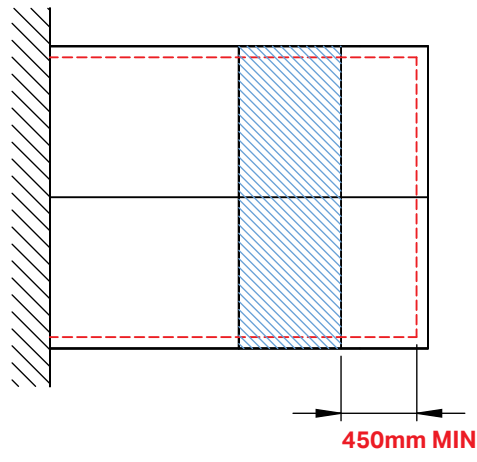

### Gable roof with standard soffit

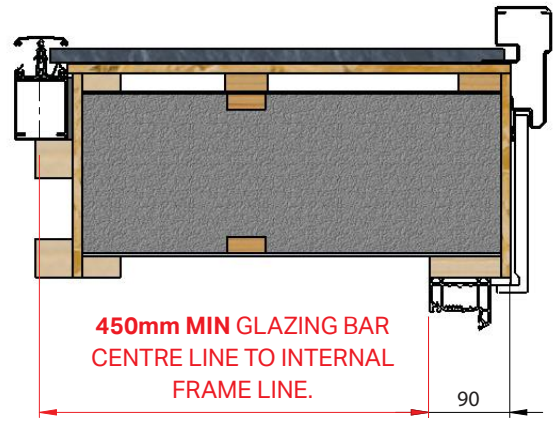

### Gable roof with extended soffit

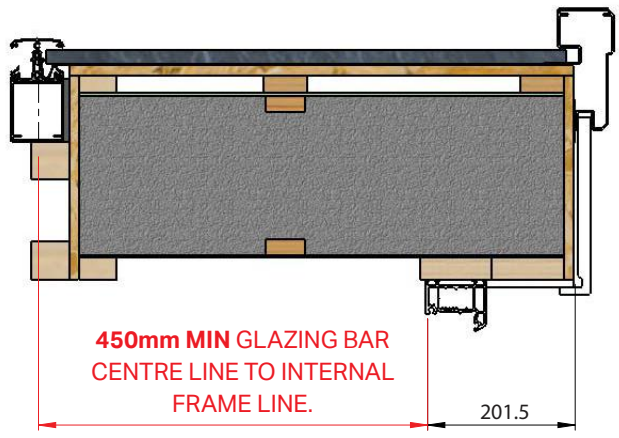



# INTEGRATED GLAZING RULES

## USING GLAZING AND CASSETTE



An alternative to fully glazed panels on UltraRoof is the option of Velux roof windows. These can be used to overcome issues in the design such as tapered box gutters or just as an alternative to a fully glazed panel. To cater for a Velux, UltraRoof uses a cassette in place of a panel to enable it to be fitted into a desired position. The following shows the rules around cassette positions on an UltraRoof380.

### Solid panel at host wall. Cassette's adjacent

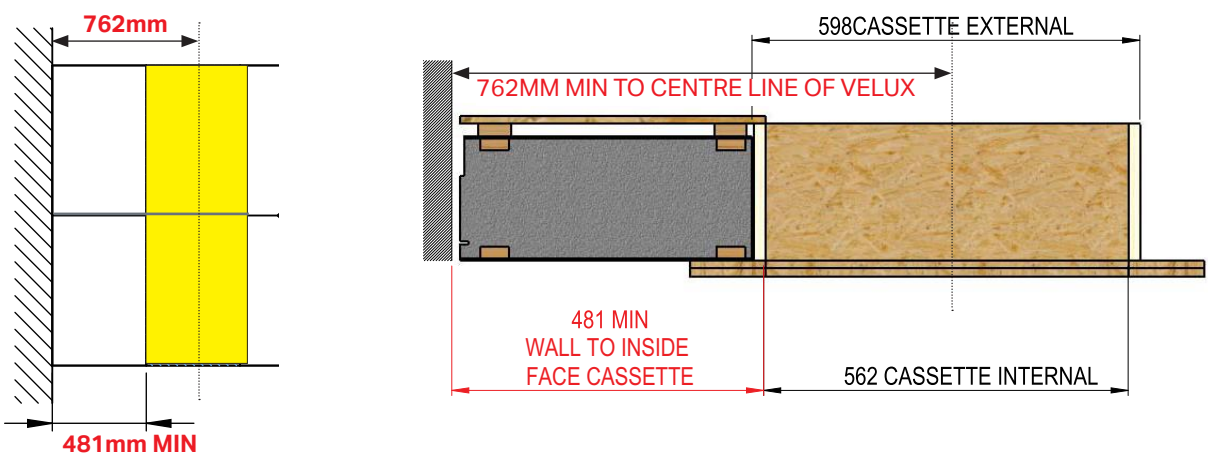

### Solid panel between cassette and integrated glazing (Solid panel must be separate cassette and integrated glass)

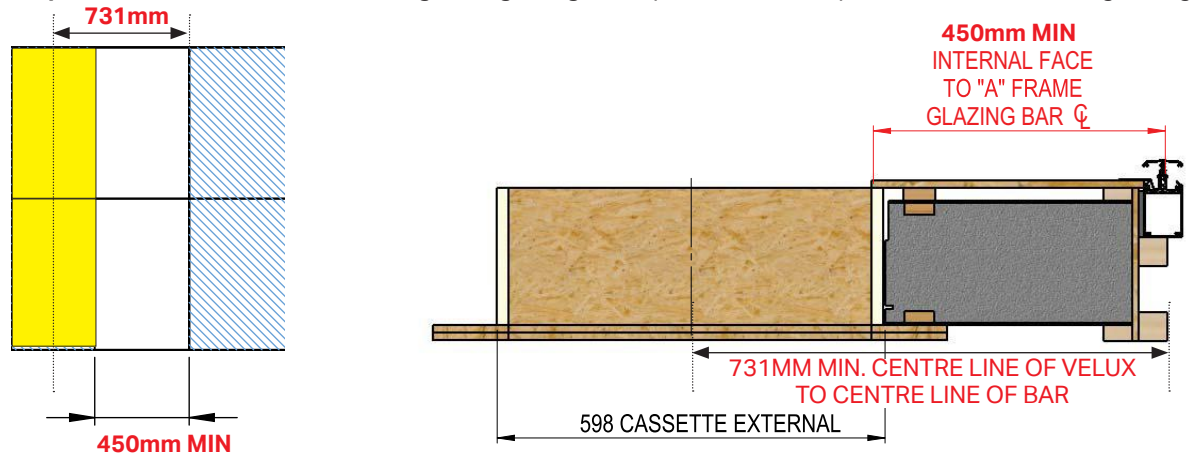

### Solid panel between cassettes (Cassettes must be separated with solid panels)

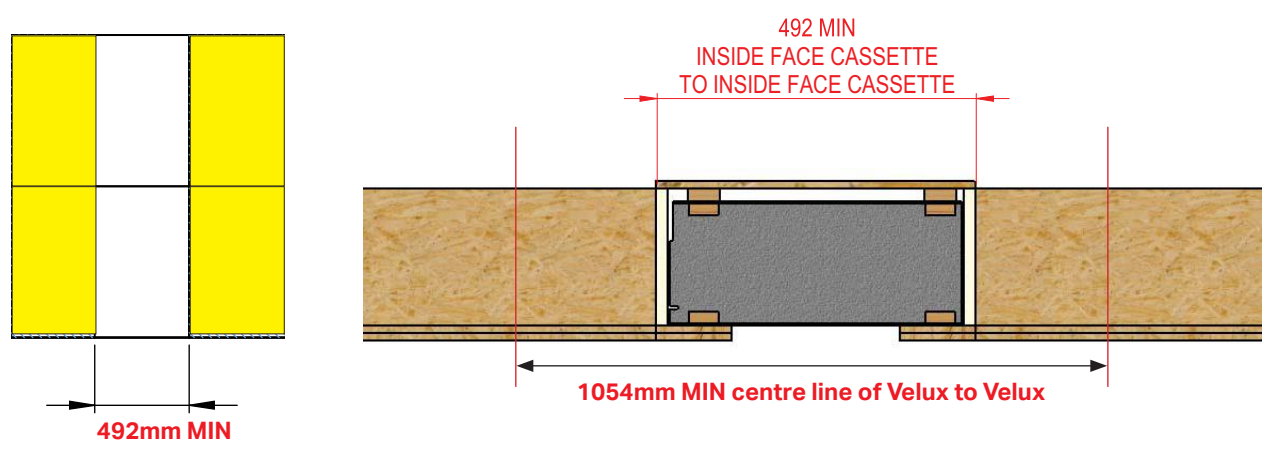

## CHOOSING APPROPRIATE BOX GUTTER AND SUPPORT

Some box gutters may need internal beam support (See page 35). If the customer wishes to change the box gutter types to avoid internal support this may restrict the placement of the glass. On some roofs there may be a trade off between internal support and glass placement. Please read pages 47-55 and discuss this with the customer.

Use these pages to ensure you have a combination that works.  
When replacng roofs with a boxgutter see pages 77-82.

### STANDARD BOX GUTTER

Standard boxbeam needs structural support. When a 265mm box gutter is used if the length of the boxgutter exceeds 4m and additional support is required. See pages 47-56.

**A**

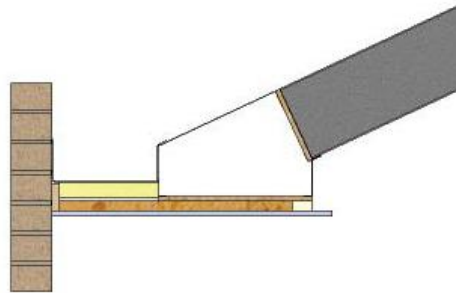

### STANDARD TAPERED BOX GUTTER

When a tapered box gutter is used the box beam is always supported by a wall mounted angle bracket that runs along the length of the beam. This instance does not require structural support.

**B**

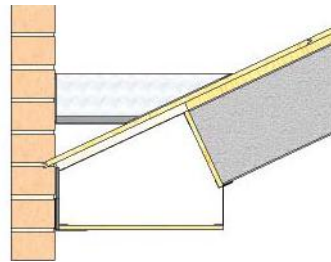

### BOX BEAM ON WINDOW FRAME

The box beam is always supported by the window frame that runs along the length of the beam. This instance does not require structural support. The beam requires support every 4m. In addition to the frames. This support may come from either a frame coupler or corner post.

**C**

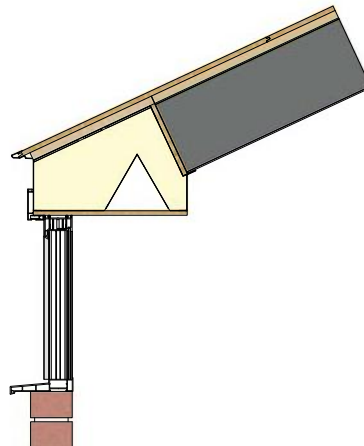

### BOX BEAM ON BRICK WORK

The box beam is always supported by the brick work that runs along the length of the beam or window frames in openings in the brickwork. This instance does not require structural support.

**D**

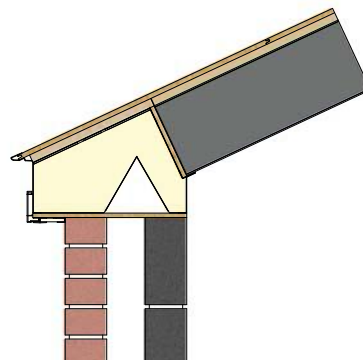

## CHOOSING APPROPRIATE BOX GUTTER AND SUPPORT

	Requires additional structural support (see options)	GLAZING top to bottom	VELUX dependent on roof size	Corner condition LEFT mirrored for right
	NO	YES	YES	<b>A</b>
	NO	NO	YES	<b>B</b>
	YES	YES	YES	<b>A</b> <b>C/D</b>
	NO	B = NO C/D = YES	YES	<b>B</b> <b>C/D</b>
	YES	YES	YES	<b>A</b> <b>A</b>
	NO	NO	YES	<b>B</b> <b>B</b>
	YES	A = YES B = NO	YES	<b>A</b> <b>B</b>

Host Wall

Box Beam

265 box gutter

Tapered box gutter

# VELUX WINDOWS - ROOF WINDOW SIZE CODE

Ultraframe recommends Velux roof windows for use in UltraRoof380. The codes below eg. CK02 can be referenced in the Velux brochure and sourced in your local trade intermediary / merchant / specialist.

p36-42 explains which Velux window (and how many) can be inserted into your preferred extension style (rules are for each elevation) which is influenced by the roof's width, projection and loadings.

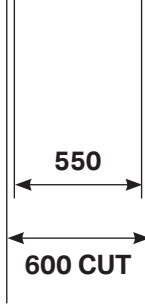
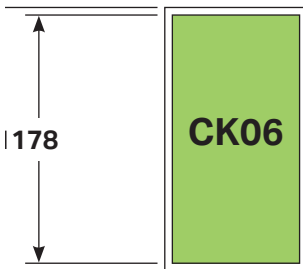
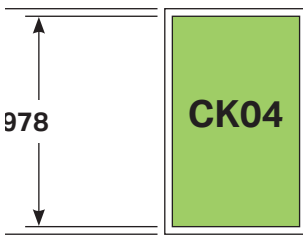

**PLEASE ENSURE YOU ORDER APPROPRIATE EDL FLASHING KIT (NOT SUPPLIED BY ULTRAFRAME)**



## GEORGIAN WINDOW OPTIONS

Chart below for single and double window options only for more options check with U-design or Ultraframe - **N.B. ROOF WINDOW OPTIONS MUST BE CHECKED BY U-DESIGN**



One of this specified Velux can be used in this elevation

Two of this specified Velux can be used in this elevation

Width between Box Beam

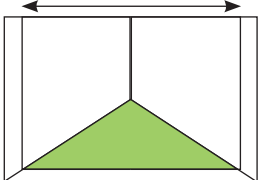

Width between Box Beam

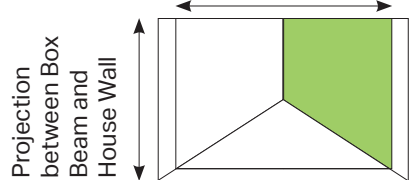

GEORGIAN FRONT ROOF WINDOW OPTIONS						
WIDTH	ROOF PITCH	VELUX OPTION AVAILABLE				
		PK25	CK01	CK02	CK04	CK06
3m	15° - 45°					
3.5m	15° - 45°					
4m	15°					
	20°					
	25°					
	30°					
	35°					
	40°					
	45°					
4.5m	15°					
	20°					
	25°					
	30°					
	35°					
	40°					
	45°					
5m	15°					
	20°					
	25°					
	30°					
	35°					
	40°					
	45°					
5.5m	15°					
	20°					
	25°					

GEORGIAN SIDE ROOF WINDOW OPTIONS							
PROJECTION	WIDTH	ROOF PITCH	VELUX OPTION AVAILABLE				
			PK25	CK01	CK02	CK04	CK06
2.5m	3m	15° - 45°					
3m	3m	15°					
		20°					
		25°					
		30°					
		35°					
		40°					
		45°					
3.5m	3m	15°					
		20°					
		25°					
		30°					
		35°					
		40°					
		45°					
4m	3m	15°					
		20°					
		25°					
		30°					
		35°					
		40°					
		45°					
4.5m	3m	15°					
		20°					
		25°					
		30°					
		35°					
		40°					
		45°					
5m	3m	15°					
		20°					
		25°					
		30°					
		35°					
		40°					
		45°					

## GEORGIAN WINDOW OPTIONS

Chart below for single and double window options only for more options check with U-design or Ultraframe - **N.B. ROOF WINDOW OPTIONS MUST BE CHECKED BY U-DESIGN**



One of this specified Velux can be used in this elevation

2 Two of this specified Velux can be used in this elevation

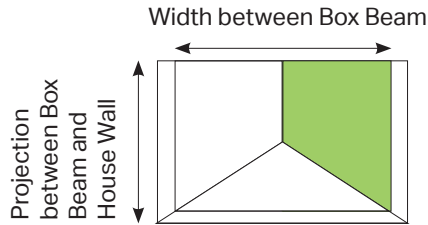
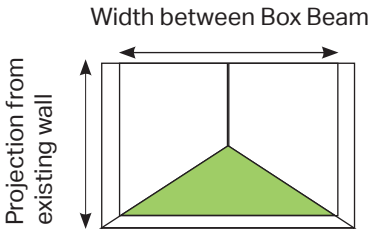

GEORGIAN SIDE ROOF WINDOW OPTIONS							
PROJECTION	WIDTH	ROOF PITCH	VELUX OPTION AVAILABLE				
			PK25	CK01	CK02	CK04	CK06
2.5m	3.5m	15° - 45°					
3m	3.5m	15°					
		20°					
		25°					
		30°					
		35°					
		40°					
		45°					
3.5m	3.5m	15°					
		20°					
		25°					
		30°					
		35°					
		40°					
		45°					
4m	3.5m	15°					
		20°		2			
		25°		2			
		30°		2	2		
		35°		2	2		
		40°		2	2	2	
		45°		2	2	2	2
4.5m	3.5m	15°		2	2	2	
		20°		2	2	2	2
		25°		2	2	2	2
		30°		2	2	2	2
		35°		2	2	2	2
		40°		2	2	2	2
		45°		2	2	2	2
5m	3.5m	15°		2	2	2	
		20°		2	2	2	2
		25°		2	2	2	2
		30°		2	2	2	2
		35°		2	2	2	2
		40°		2	2	2	2
		45°		2	2	2	2

GEORGIAN SIDE ROOF WINDOW OPTIONS							
PROJECTION	WIDTH	ROOF PITCH	VELUX OPTION AVAILABLE				
			PK25	CK01	CK02	CK04	CK06
2.5m	4m	15° - 45°					
3m	4m	15°					
		20°					
		25°					
		30°					
		35°					
		40°					
		45°					
3.5m	4m	15°					
		20°					
		25°					
		30°					
		35°					
		40°					
		45°					
4m	4m	15°					
		20°		2			
		25°		2			
		30°		2	2		
		35°		2	2		
		40°		2	2	2	
		45°		2	2	2	2
4.5m	4m	15°		2	2	2	
		20°		2	2	2	2
		25°		2	2	2	2
		30°		2	2	2	2
		35°		2	2	2	2
		40°		2	2	2	2
		45°		2	2	2	2
5m	4m	15°		2	2	2	2
		20°		2	2	2	2
		25°		2	2	2	2
		30°		2	2	2	2
		35°		2	2	2	2
		40°		2	2	2	2
		45°		2	2	2	2

## GEORGIAN WINDOW OPTIONS

Chart below for single and double window options only for more options check with U-design or Ultraframe - **N.B. ROOF WINDOW OPTIONS MUST BE CHECKED BY U-DESIGN**



One of this specified Velux can be used in this elevation

2 Two of this specified Velux can be used in this elevation

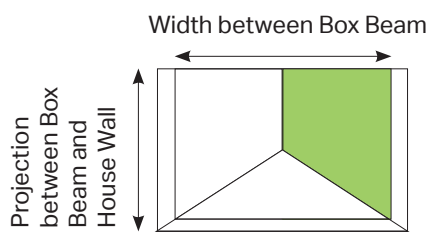
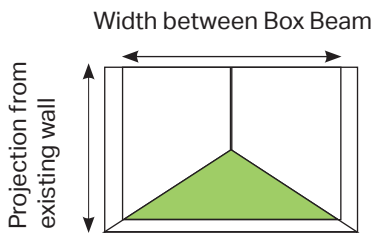

GEORGIAN SIDE ROOF WINDOW OPTIONS							
PROJECTION	WIDTH	ROOF PITCH	VELUX OPTION AVAILABLE				
			PK25	CK01	CK02	CK04	CK06
2.5m	4.5m	15° - 45°					
3m	4.5m	15°					
		20°					
		25°					
		30°					
		35°					
		40°					
		45°					
3.5m	4.5m	15°					
		20°					
		25°					
		30°					
		35°					
		40°					
		45°					
4m	4.5m	15°					
		20°		2			
		25°		2			
		30°		2	2		
		35°		2	2		
		40°		2	2	2	
		45°		2	2	2	2
4.5m	4.5m	15°		2	2	2	
		20°		2	2	2	2
		25°		2	2	2	2
		30°		2	2	2	2
		35°		2	2	2	2
		40°		2	2	2	2
		45°		2	2	2	2
5m	4.5m	15°		2	2	2	2
		20°		2	2	2	2
		25°		2	2	2	2
		30°		2	2	2	2
		35°		2	2	2	2
		40°		2	2	2	2
		45°		2	2	2	2

GEORGIAN SIDE ROOF WINDOW OPTIONS							
PROJECTION	WIDTH	ROOF PITCH	VELUX OPTION AVAILABLE				
			PK25	CK01	CK02	CK04	CK06
2.5m	5m	15° - 45°					
3m	5m	15°					
		20°					
		25°					
		30°					
		35°					
		40°					
		45°					
3.5m	5m	15°					
		20°					
		25°					
		30°					
		35°					
		40°					
		45°					
4m	5m	15°					
		20°		2			
		25°		2			
		30°		2	2		
		35°		2	2		
		40°		2	2	2	
		45°		2	2	2	2
4.5m	5m	15°		2	2	2	
		20°		2	2	2	2
		25°		2	2	2	2
		30°		2	2	2	2
		35°		2	2	2	2
		40°		2	2	2	2
		45°		2	2	2	2
5m	5m	15°		2	2	2	2
		20°		2	2	2	2
		25°		2	2	2	2
		30°		2	2	2	2
		35°		2	2	2	2
		40°		2	2	2	2
		45°		2	2	2	2

## HIPPED LEAN TO WINDOW OPTIONS

Chart below for single and double window options only for more options check with U-design or Ultraframe - **N.B. ROOF WINDOW OPTIONS MUST BE CHECKED BY U-DESIGN**



  One of this specified Velux can be used in this elevation
 
2 Two of this specified Velux can be used in this elevation

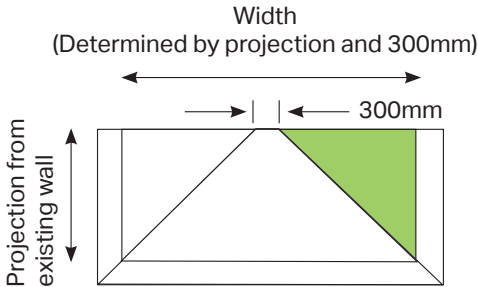

HIPPED LEAN-TO SIDE ROOF WINDOW OPTIONS							
PROJECTION	WIDTH	ROOF PITCH	VELUX OPTION AVAILABLE				
			PK25	CK01	CK02	CK04	CK06
2.5m	-	15° - 45°					
3m	-	15°					
		20°					
		25°					
		30°					
		35°					
		40°					
		45°					
3.2m	-	15°					
		20°					
		25°					
		30°					
		35°					
		45°					
3.5m	-	15°					
		20°					
		45°					

HIPPED LEAN-TO SIDE ROOF WINDOW OPTIONS							
PROJECTION	WIDTH	ROOF PITCH	VELUX OPTION AVAILABLE				
			PK25	CK01	CK02	CK04	CK06
2.5m	5060mm	15°					
		20°					
		25°					
		30°					
		35°		2	2		
		40°		2	2		
		45°		2	2	2	
2.5m	5.5m	15°		2			
		20°		2	2		
		25°		2	2		
		30°		2	2		
		35°		2	2	2	
		40°		2	2	2	2
		45°		2	2	2	2
2.5m	6m	15°		2	2	2	
		20°		2	2	2	
		25°		2	2	2	
		30°		2	2	2	2
		35°		2	2	2	2
		40°		2	2	2	2
		45°		2	2	2	2
2.5m	6.5m	15°		2	2	2	2
		20°		2	2	2	2
		25°		2	2	2	2
		30°		2	2	2	2
		35°		2	2	2	2
		40°		2	2	2	2
		45°		2	2	2	2
2.5m	7m	15°		2	2	2	2
		20°		2	2	2	2
		25°		2	2	2	2
		30°		2	2	2	2
		35°		2	2	2	2
		40°		2	2	2	2
		45°		2	2	2	2



# HIPPED LEAN TO WINDOW OPTIONS

Chart below for single and double window options only for more options check with U-design or Ultraframe - **N.B. ROOF WINDOW OPTIONS MUST BE CHECKED BY U-DESIGN**



- One of this specified Velux can be used in this elevation
- 2 Two of this specified Velux can be used in this elevation

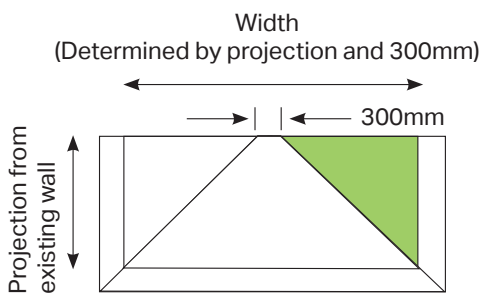

HIPPED LEAN-TO SIDE ROOF WINDOW OPTIONS							
PROJECTION	WIDTH	ROOF PITCH	VELUX OPTION AVAILABLE				
			PK25	CK01	CK02	CK04	CK06
3m	6060mm	15°		2	2	2	
		20°		2	2	2	
		25°		2	2	2	2
		30°		2	2	2	2
		35°		2	2	2	2
		40°		2	2	2	2
		45°		2	2	2	2
3m	6.5m	15° - 45°		2	2	2	2
3m	7m	15°		2	2	2	2
		20°		2	2	2	2
		45°		2	2	2	2

3.2m	6464mm	15°		2	2	2	2
		20°		2	2	2	2
		25°		2	2	2	2
		30°		2	2	2	2
		35°		2	2	2	2
		40°		2	2	2	2
		45°		2	2	2	2
3.2m	7m	15° - 45°		2	2	2	2
3.2m	7.5m	15°		2	2	2	2
		20°		2	2	2	2
		45°		2	2	2	2

3.5m	7060mm	15°		2	2	2	2
		20°		2	2	2	2
		25°		2	2	2	2
3.5m	7.5m	15°		2	2	2	2
		20°		2	2	2	2
		25°		2	2	2	2
3.5m	8m	15°		2	2	2	2
		20°		2	2	2	2
		25°		2	2	2	2

## GABLE FRONT ROOF WINDOW OPTIONS

Chart below for single and double window options only for more options check with U-design or Ultraframe - **N.B. ROOF WINDOW OPTIONS MUST BE CHECKED BY U-DESIGN**



One of this specified Velux can be used in this elevation

2 Two of this specified Velux can be used in this elevation

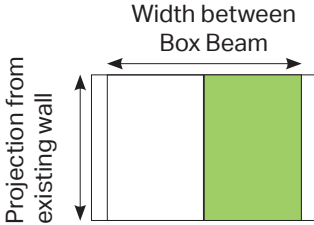

GABLE FRONT ROOF WINDOW OPTIONS							GABLE FRONT ROOF WINDOW OPTIONS								
PROJECTION	WIDTH	ROOF PITCH	VELUX OPTION AVAILABLE					PROJECTION	WIDTH	ROOF PITCH	VELUX OPTION AVAILABLE				
			PK25	CK01	CK02	CK04	CK06				PK25	CK01	CK02	CK04	CK06
2.5m	2.5m	15°						3m	2.5m	15°					
		20°													
		25°													
		30°									2				
		35°									2	2			
		40°									2	2			
		45°									2	2	2		
2.5m	3m	15°						3m	3m	15°		2	2		
		20°								2	2				
		25°								2	2				
		30°									2	2	2		
		35°									2	2	2		
		40°										2	2	2	2
		45°										2	2	2	2
2.5m	3.5m	15°						3m	3.5m	15°		2	2	2	
		20°									2	2	2	2	
		25°									2	2	2	2	
		30°									2	2	2	2	2
		35°									2	2	2	2	2
		40°									2	2	2	2	2
		45°									2	2	2	2	2
2.5m	4m	15°						3m	4m	15°		2	2	2	2
		20°									2	2	2	2	
		25°									2	2	2	2	
		30°									2	2	2	2	2
		35°									2	2	2	2	2
		40°									2	2	2	2	2
		45°									2	2	2	2	2
2.5m	4.5m	15°						3m	4.5m	15°		2	2	2	2
		20°									2	2	2	2	
		25°									2	2	2	2	
		30°									2	2	2	2	2
		35°									2	2	2	2	2
		40°									2	2	2	2	2
		45°									2	2	2	2	2

### MAXIMUM ROOF SIZES AND STRUCTURAL PERFORMANCE

All sizes relate to the internal window frame consistent with conservatory standard set out. The maximum unsupported beam span is 4m - any bi-folding doors used **MUST** be bottom supported and not top hung.

**MAX BEAM LENGTH FOR ALL OF THE DESIGNS IS 7000MM**

#### Victorian/Gable/Georgian/Edwardian

	Pitch 15° - 21°		Pitch 22° - 29°		Pitch 30° - 40°	
	Width (mm)	Projection (mm)	Width (mm)	Projection (mm)	Width (mm)	Projection (mm)
Max Size	6500	5000	6700	5000	6500	5000
At Loadings	Wind 1.35kN	Snow 0.7kN	Wind 1.5kN	Snow 0.89kN	Wind 1.65kN	Snow 0.8kN

Min ridge length = 300mm

#### Lean-to

	Pitch 12.5° - 29°		Pitch 30° - 40°	
	Width (mm)	Projection (mm)	Width (mm)	Projection (mm)
Max Size	7000	4000	7000	3700
At Loadings	Wind 1.4kN	Snow 0.75kN	Wind 1.15kN	Snow 0.75kN

Min ridge length = 300mm

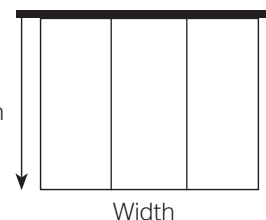
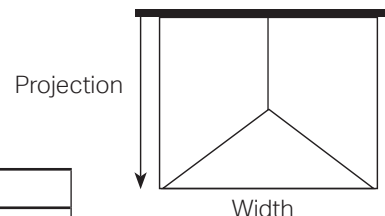

#### Hipped Lean-to

	Pitch 15° - 29°		Pitch 29° - 40°	
	Width (mm)	Projection (mm)	Width (mm)	Projection (mm)
Max Size	7000	3500	7000	3200
At Loadings	Wind 1.4kN	Snow 1.1kN	Wind 1.3kN	Snow 0.6kN

Min ridge length = 300mm

Min wall plate length on a single hip = 300mm

#### Double Hipped Georgian

	Pitch 15° - 29°		Pitch 30° - 40°	
	Hip Width (mm)	Projection Length (mm)	Width (mm)	Projection (mm)
Max Size	5600	No limits	4300	No limits
At Loadings	Wind 1.35kN	Snow 0.7kN	Wind 1.5kN	Snow 0.89kN

Min ridge length on a double hip = 600mm

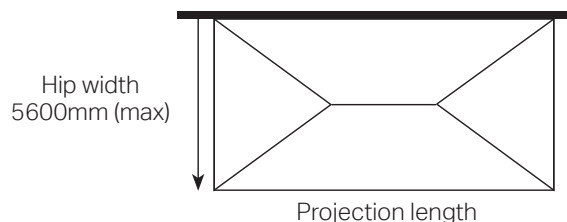

## USING THIS GUIDE TO DECIDE ON STRUCTURAL LOADS - WORKED EXAMPLE

**The only accurate way to specify UltraRoof380 is using U-Design software.**

Either use a licensed copy of the software or send a sketch to Ultraframe or one of its approved trade intermediaries / distributors, where the information will be input on your behalf.

### Worked Example

**A 4m x 4m\* Georgian conservatory at 25 degree is being re-roofed at the rear of a semi-detached property in the small market town of Clitheroe. The homeowner wants to know if they can have Velux roof windows and what size and how many.**

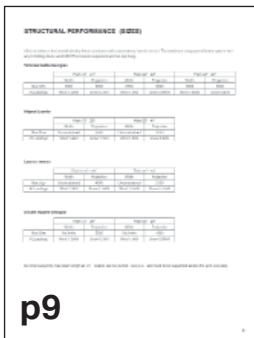

Turn to page 43, the correct page for the style of extension (in this case Georgian) and use the chart that shows the pitch range (defined as 25° for this project) .As the project is defined as 4m x 4m, look up the loading for this size which shows UltraRoof380 can accept a load of 1.5kN/m<sup>2</sup> from wind and 0.89kN/m<sup>2</sup> from snow.

Now check how high above sea level the location is (Google search or try [www.maps-streetview.com](http://www.maps-streetview.com)) – in this case it's 76m elevation above the sea level. As outlined in the worked example in red above, the location is in a small town (not the country).



Use figure 1, page 45 to check the wind speed at the location (in this case its 23 m/s which translates on table 1 to 0.68 kN/m<sup>2</sup>). From figure 2, page 46 check the snow load at the location (which is 0.6kN/m<sup>2</sup>).



Both figures at the actual site are within the design parameters of the UltraRoof380 system, so it is OK to proceed with the project with no amendments.

And finally, to determine the number and size of Velux roof windows that can fit into this extension, turn to pages 37-39 for front elevation and side elevation to look up the vent opening sizes that can be configured into each elevation.

	Loads at postcode (kN/m <sup>2</sup> )	Max System Load (kN/m <sup>2</sup> )	System load MUST EQUAL or EXCEED post code load
<b>SNOW</b>	0.60	0.89	✓
<b>WIND</b>	0.68	1.15	✓

**If you are unable to achieve the desired size for your UltraRoof380 project please contact Ultraframe's Technical Support Team for advice on 01200 452 918**

## STRUCTURAL SPECIFICATION GUIDELINES

### The size limitation for UltraRoof380 is limited by the projects geographic location.

The location of each project will determine the imposed loads on the finished structure (both wind and snow loadings will have an impact). The size of these loads can be obtained from U-design software as the roof is being specified. U-design uses historic weather datafiles which from a postcode can provide both wind and snow loadings. If you do not have access to U-design the maps will help **guide** you to the approximate loadings. This will not give you exact values but ones likely to be the worst case for your location.

If you are unable to achieve the desired size for your UltraRoof380 project please contact Ultraframe's Technical Support Team for advice on 01200 452 918.

The Map in figure 1 (overleaf) shows the fundamental basic wind velocity map in  $v_b$  m/s. Find your approximate location and determine wind speed.

Now you need the height above sea level in metres - this information could be obtained via Ordnance Survey or Google Maps. Decide if your site is town or country.

Now use Table 1 Below to establish the load in  $kN/m^2$  and finally, check with figure 2 to see the snow load.

Table 1 Max wind Load EC1-4-NA -  $q(p)$   $kN/m^2$

Altitude		21.5	22	22.5	23	23.5	24	24.5	25	25.5	26	26.5	27	27.5	28	28.5	29	29.5
TOWN	50	0.55	0.57	0.60	0.62	0.65	0.68	0.71	0.74	0.77	0.80	0.83	0.86	0.89	0.92	0.96	0.99	1.03
	100	0.60	0.63	0.66	0.68	0.72	0.75	0.78	0.81	0.84	0.88	0.91	0.94	0.98	1.02	1.05	1.09	1.13
	150	0.65	0.68	0.72	0.75	0.78	0.82	0.85	0.88	0.92	0.96	0.99	1.03	1.07	1.11	1.15	1.19	1.23
	200	0.71	0.75	0.78	0.82	0.85	0.89	0.92	0.96	1.00	1.04	1.08	1.12	1.17	1.21	1.25	1.30	1.34
	250	0.77	0.81	0.85	0.88	0.92	0.96	1.00	1.04	1.09	1.13	1.17	1.22	1.26	1.31	1.36	1.41	1.46
	300	0.84	0.88	0.92	0.96	1.00	1.04	1.09	1.13	1.18	1.22	1.27	1.32	1.37	1.42	1.47	1.52	1.57
COUNTRY	50	0.63	0.66	0.69	0.72	0.75	0.78	0.81	0.85	0.88	0.92	0.95	0.99	1.03	1.06	1.10	1.14	1.18
	100	0.69	0.72	0.75	0.79	0.82	0.86	0.89	0.93	0.97	1.01	1.05	1.08	1.13	1.17	1.21	1.25	1.30
	150	0.75	0.79	0.82	0.86	0.90	0.94	0.98	1.02	1.06	1.10	1.14	1.19	1.23	1.28	1.32	1.37	1.42
	200	0.82	0.86	0.90	0.94	0.98	1.02	1.06	1.11	1.15	1.20	1.24	1.29	1.34	1.39	1.44	1.49	1.54
	250	0.89	0.93	0.97	1.02	1.06	1.11	1.15	1.20	1.25	1.30	1.35	1.40	1.45	1.51	1.56	1.62	1.67
	300	0.96	1.01	1.05	1.10	1.15	1.20	1.25	1.30	1.35	1.41	1.46	1.52	1.57	1.63	1.69	1.75	1.81



## STRUCTURAL SPECIFICATION GUIDELINES

**Figure 1**  
Fundamental  
basic wind  
velocity,  
 $v_{b,map}$  in m/s

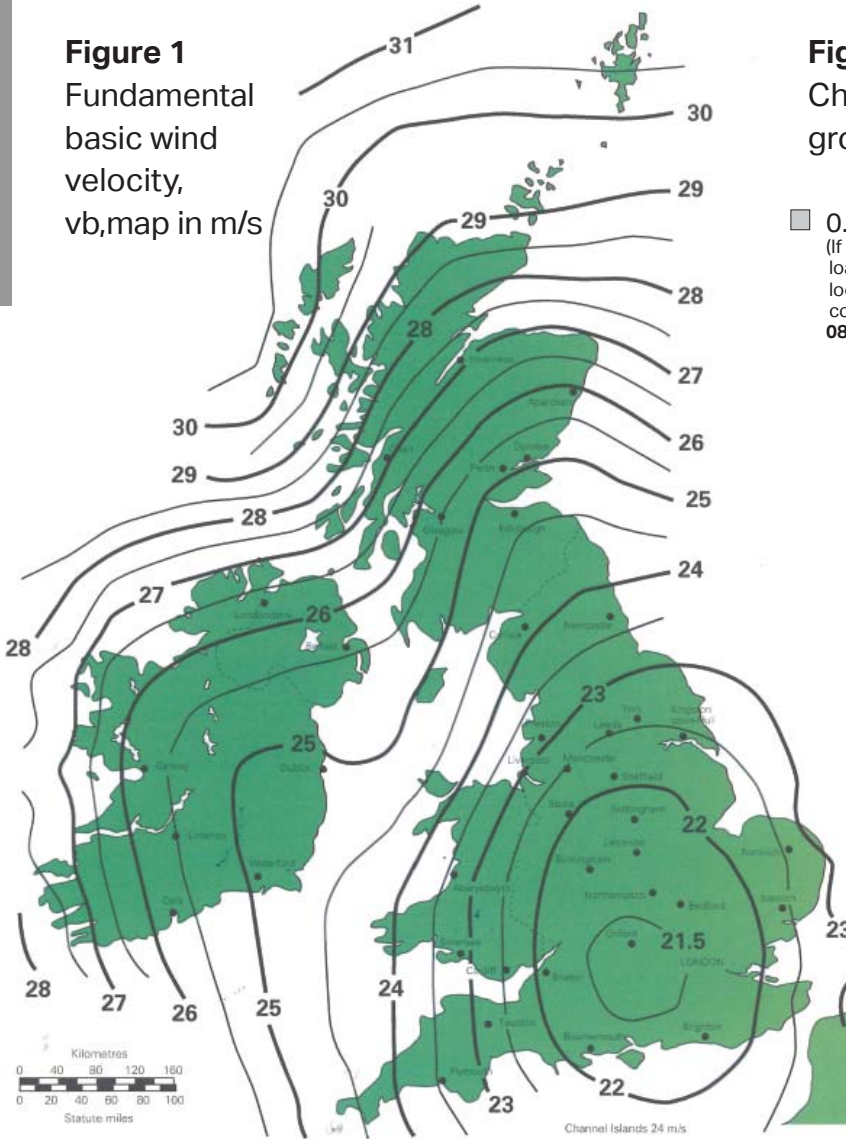

**Figure 2**  
Characteristic  
ground snow load

■ 0.8 AREA.  
(If in doubt about  
loadings at your  
location, please  
contact us on  
**0843 208 6930**)



\* SOURCE: Euro Codes

↓  
Remainder  
of UK = 0.6

### IMPORTANT - NOTE 1

The installer is responsible for ensuring that where UltraRoof380 is supported by means such as timber frame walls, the structure provides enough lateral support and resistance to wind uplift. Further guidance can be obtained through this guides technical documentation. Ultraframe cannot be responsible for the structural adequacy of any existing building work used as part of an overall conversion. While assistance is provided, ultimate responsibility to secure Building Regulations lies with the retail installer.

**IF IN DOUBT ABOUT STRUCTURAL COMPLIANCE, PLEASE CONSULT LABC, JHAI OR A STRUCTURAL ENGINEER**

### IMPORTANT - NOTE 2

This guide is intended to provide indicative information and to help you understand the design principles and applicable loadings. U-Design is the final arbiter on price and specification decisions.

### IMPORTANT - NOTE 3

The UltraRoof380 components have been designed and manufactured to meet the specification of each individual job. Any significant on site modifications particularly relating to the repositioning of any structural members will invalidate the product's warranty and compromise the structure's integrity. If adjustments are required due to site conditions please consult Ultraframe.

## STRUCTURAL SUPPORT & WHEN IT IS REQUIRED

Structural support is a vital consideration when designing the UltraRoof 380. This document highlights the many variations and options available when adding structural support and crucially determining when and how it should be used. Support is needed in order to create roofs of various sizes, allow for various obstacles/intrusions and to fit into its designed space effectively.

**If there is nothing in this document that relates to your situation then please contact our team and we can assist in working out a solution.**

UltraRoof has a series of styles and shapes that have to be supported by the box beam which in turn must be supported by window frames or connections to the host wall. When a beam is in a position where it can no longer support itself, extra structural support is needed.

The instances where beams need structural support are as follows:

### BEAM SUPPORT

A beam must be supported at both ends either by frames or masonry. The maximum unsupported span of a beam is 4m. See pages 47-56 for various support methods.

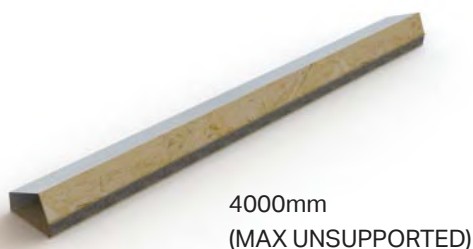

### A BOX BEAM DOES NOT CONTACT THE HOST WALL

When a beam is not supported by the host wall via a bracket of any kind, then the beam needs additional structural support.

**In this example, the box beam does not interact with the host wall and needs structural support from below.**

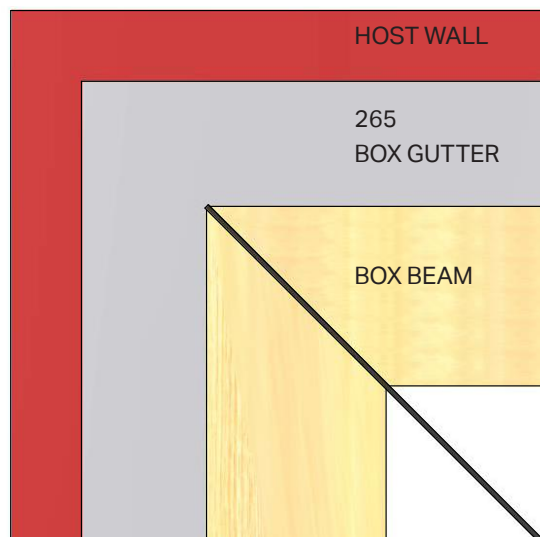

# STANDARD SUPPORT FOR STANDARD BOX BEAM

## BOX BEAM WALL BRACKET SUPPORT

### (NRW001)

First box beam brackets are fixed to the host wall in position. Beams with pre cut openings then locate on the positioned brackets.

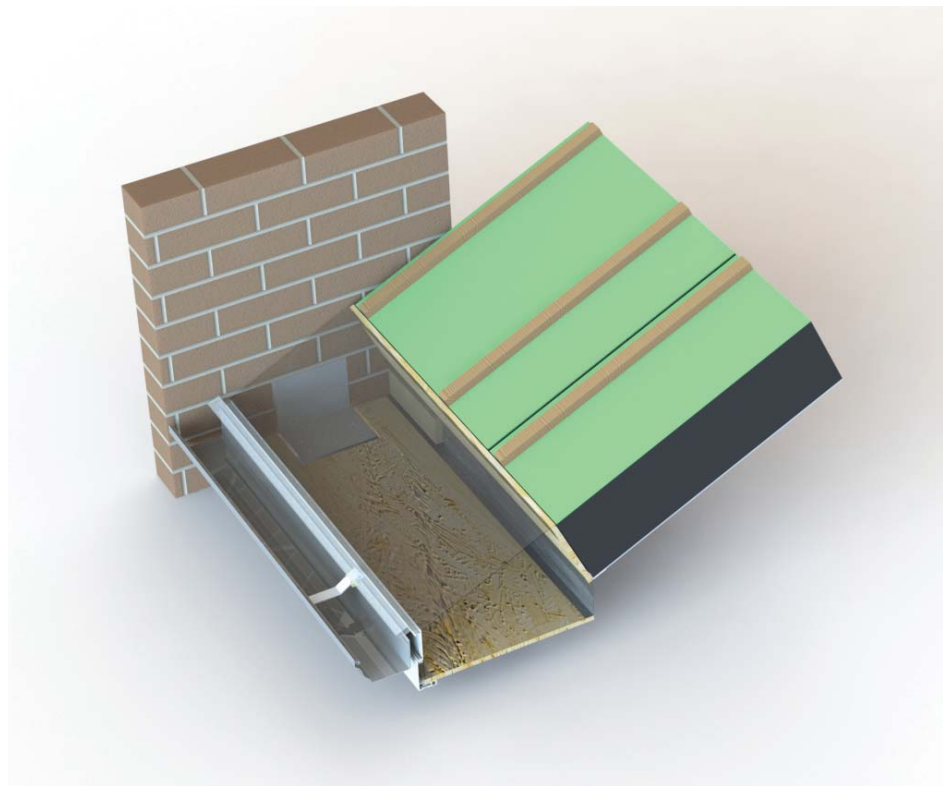
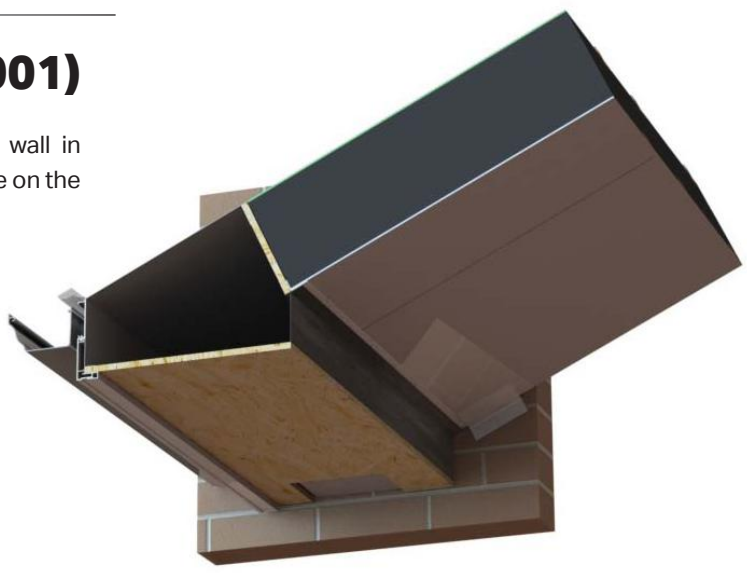

Cutaway section showing wall bracket position for standard soffit

# STANDARD SUPPORT FOR TAPERED BOX GUTTERS

When a tapered box gutter is used, the standard support for the beam is an angle bracket that is fixed to the house wall running along the length of the beam. Tapered box gutters use this support in all instances and do not require any additional structural support. (Unless being used to replace existing box gutters, see page 77-82)

## BOX BEAM ANGLED WALL BRACKET



### (RRS---/8)

Angle bracket is fixed to the wall to accommodate the full length of the box beam. This support acts as structural support, no other support required in any instance (along the length of this beam).



## PANEL ANGLED WALL BRACKETS



### (RRS---/7)

Angle bracket is fixed to the wall to accommodate the full length of the panel being fitted to the wall. This support replaces the beam and acts as structural support, no other support required in any instance (along the length of the panel). Only used for intrusions.



## BOX BEAM STRUCTURAL SUPPORT FOR 265MM BOXGUTTER

The gallows brackets can be arranged in a corner situation when both beams need to be supported. The bracket can be clad in plasterboard. Full width of box beam requires support gallows bracket 645mm from host wall to end of bracket.

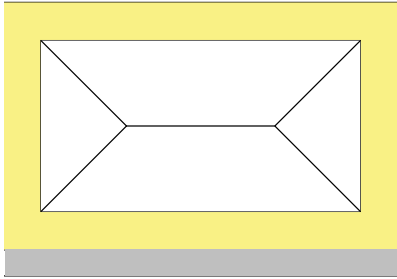

All box Beams that support a 265mm fabricated boxgutter must be supported by means of gallows brackets, posts or brick piers. Min/max. dimensions from internal frame stated below.

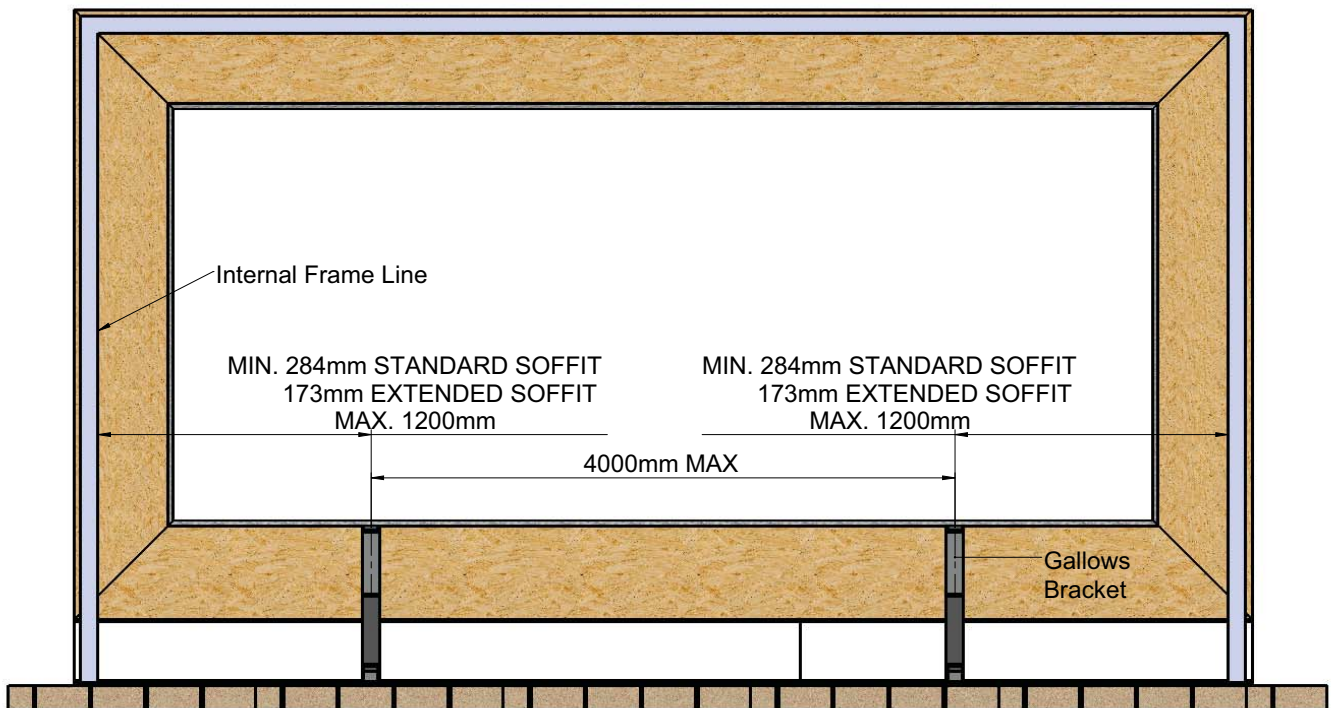

**NOTE:** Against full height vertical walls, a Tapered Boxgutter would be recommended.

NOTE: Integrated glass units can only be specified if using 265mm boxgutter.  
Velux must be used if tapered boxgutter



# STRUCTURAL SUPPORT - GALLOWS BRACKET - BUNGALOW SITUATION

The aluminium gallows bracket provides support to box beams. It covers both standard situations and extended soffit roofs. Ordered as standard size it covers the width of the box beam and box gutter. Extended gallows brackets can also be ordered.

## GALLOWS BRACKET LIMITATIONS

The bracket can be made to a bespoke size to accommodate for different size situations, but it has its limits. It can be made any size within 645mm – 1064mm. The largest soffit size a gallows bracket can cover is 419mm, anything larger then a custom bracket has to be made to suit. The bracket must cover the full depth of the beam and box gutter and any soffit (if applicable). Below shows maximum limitations of the bracket.

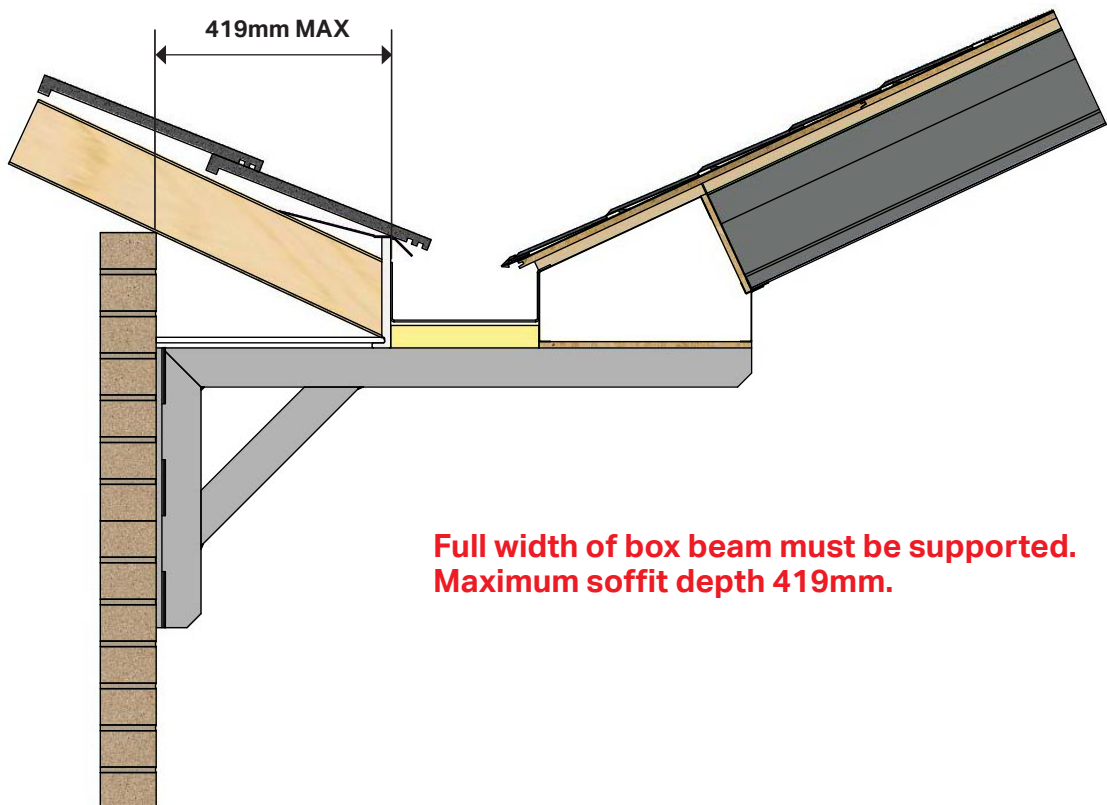

**Full width of box beam must be supported.  
Maximum soffit depth 419mm.**

## GALLOWS BRACKET - CORNER

The gallows brackets can be arranged in a corner situation when both beams need to be supported. The bracket can be clad in plasterboard. Full width of box beam requires support gallows bracket 645mm from host wall to end of bracket (see page 51).

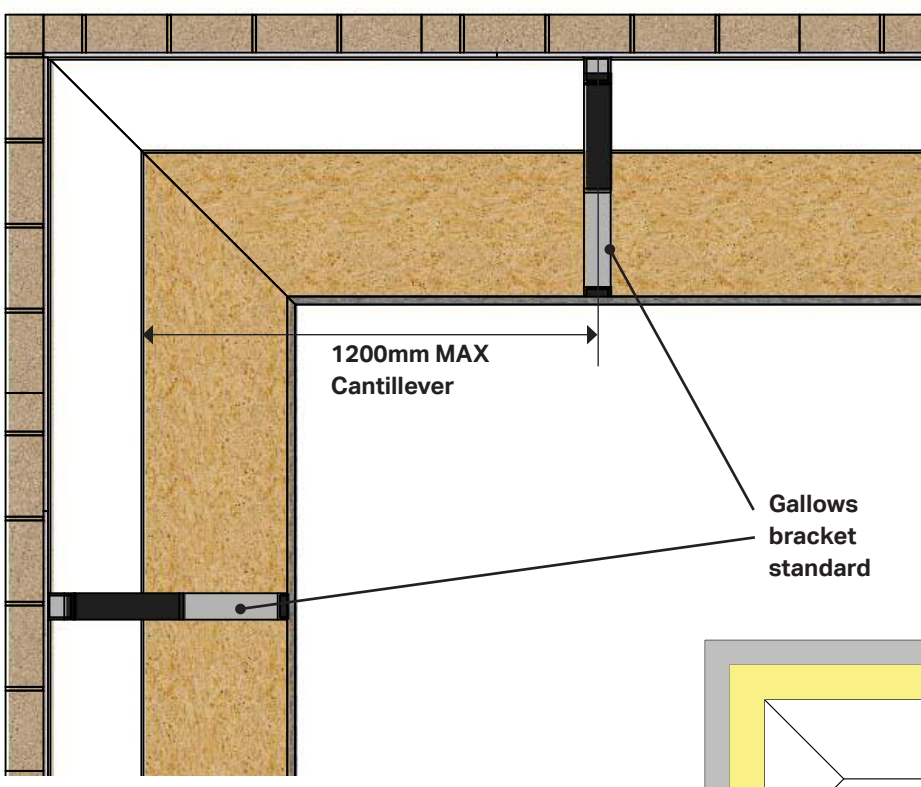

### RULES

- Maximum cantilever of 1200mm
- Gallows bracket must cover full width (box beam and box gutter width 645mm) plus any soffit on a bungalow (max bungalow soffit size 419mm).

### GALLOWS BRACKET - INTERMEDIATE

The distance between gallows brackets and other supports should not exceed 4,000mm.

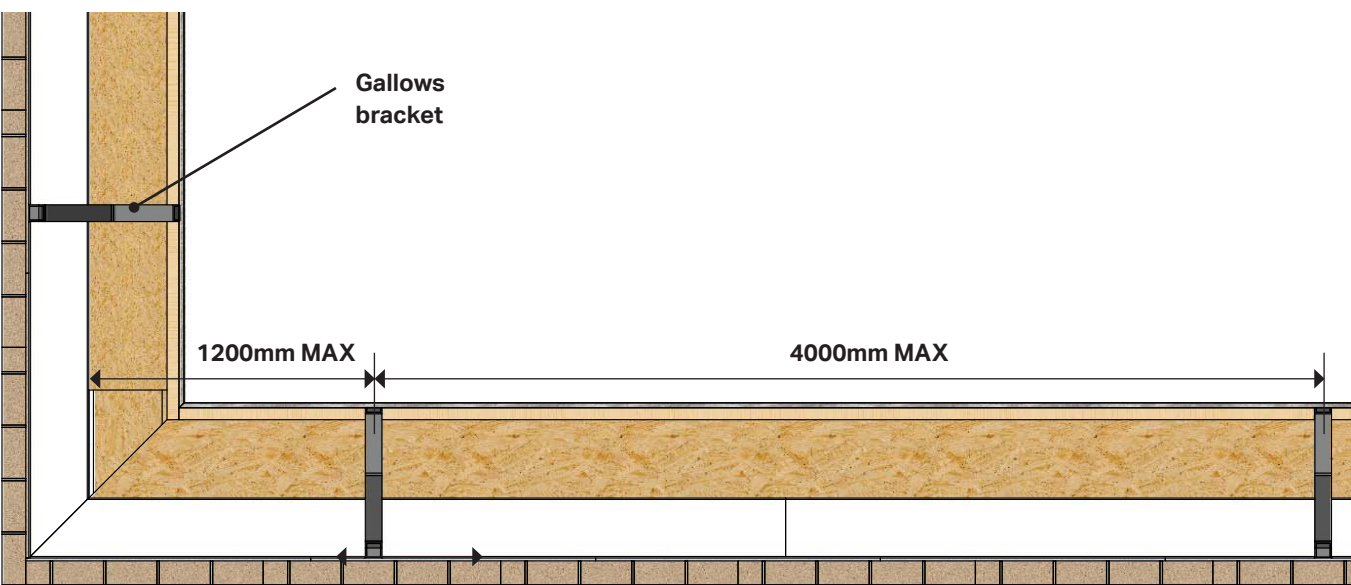

## STRUCTURAL SUPPORT - TIMBER STUD WORK

The simple and most available method of support is timber stud walling. It is quick to put up and gives a good finish.

### TIMBER COLUMN SUPPORT

The timber column is a 645x645mm, boarded internally with 12.5mm plywood and then plaster boarded on the exterior. Its compact structure makes it a neat finish in the corner of the room while providing structural support.

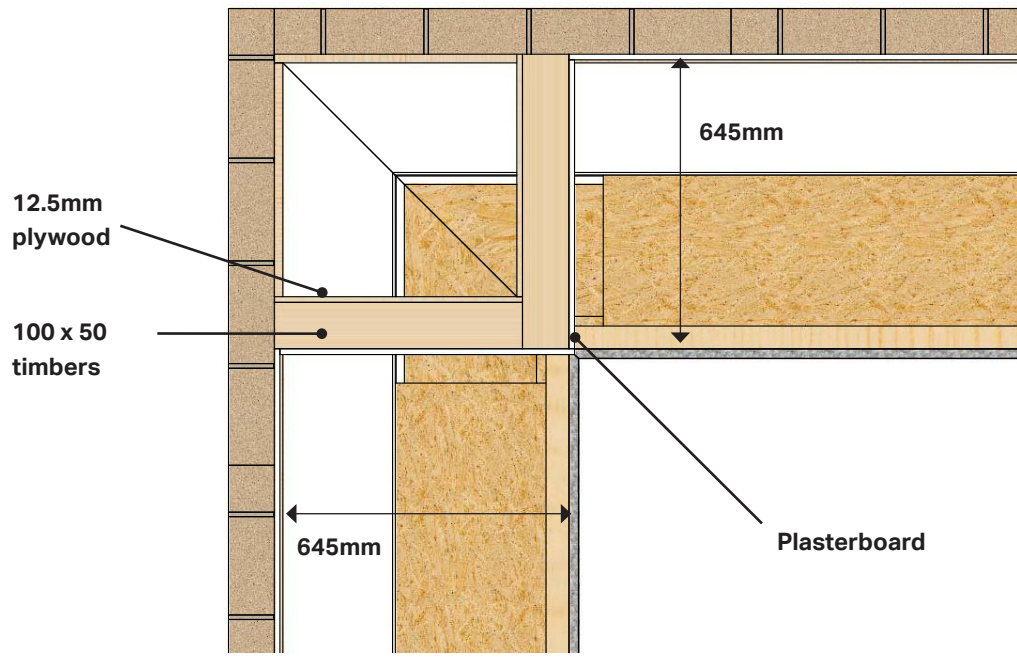

### RULES

- Stud wall must cover full width ( box beam and box gutter width 645mm)



# STRUCTURAL SUPPORT - TIMBER STUD WORK

## TIMBER CORNER SUPPORT

The timber corner supports are simple stud walls, 645mm deep that support the box beam. Each wall is boarded with 12.5mm plywood and then finished with plasterboard to its exterior.

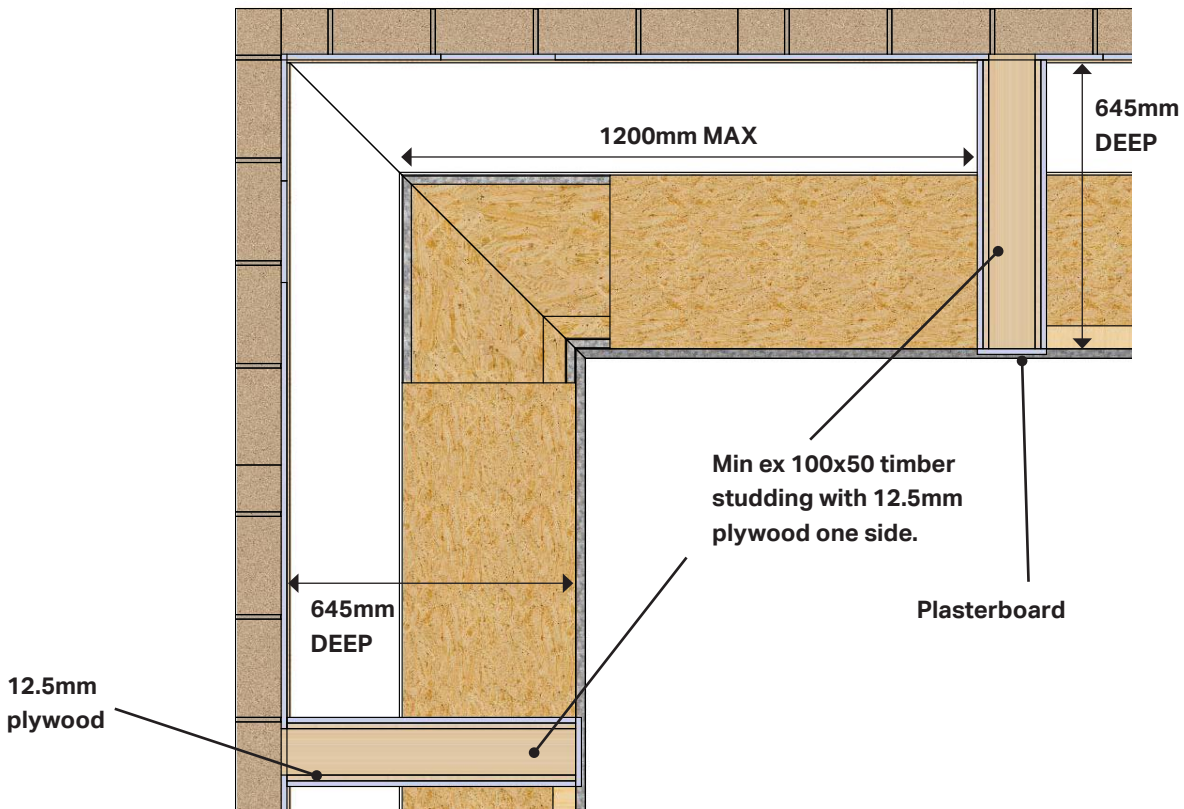
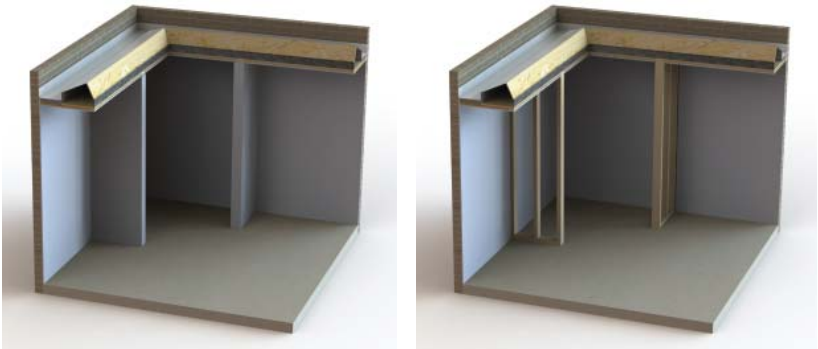

## RULES

- Maximum cantilever 1,200mm
- Stud wall must cover full width ( box beam and box gutter width 645mm)

## STRUCTURAL SUPPORT - TIMBER STUD WORK - INTERMEDIATE

The simple and most available method of support is timber stud walling. It is quick to put up and gives a good finish when using plasterboard.

### TIMBER INTERMEDIATE SUPPORT

Intermediate supports are appropriate when the box beam extends longer than 4000mm along its length before reaching the next structural support at a corner. An intermediate support is placed. A maximum of 4000mm from the previous support to carry the box beam.

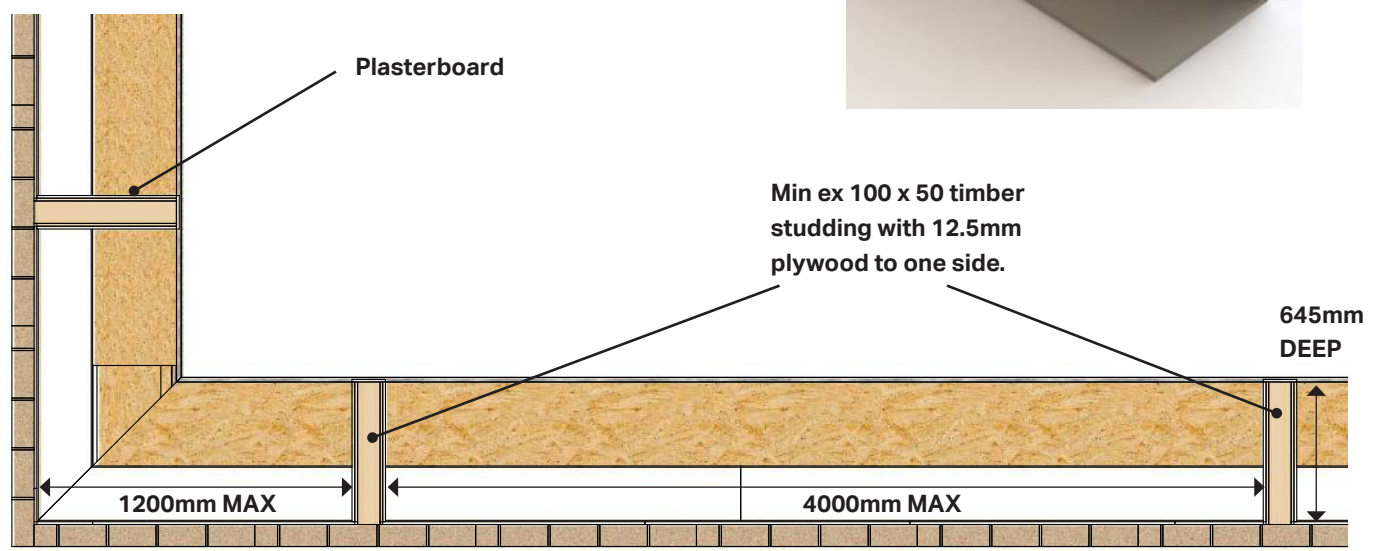
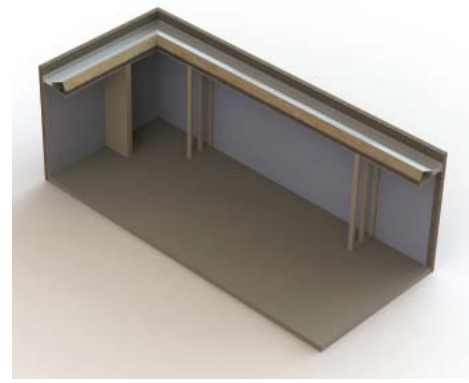
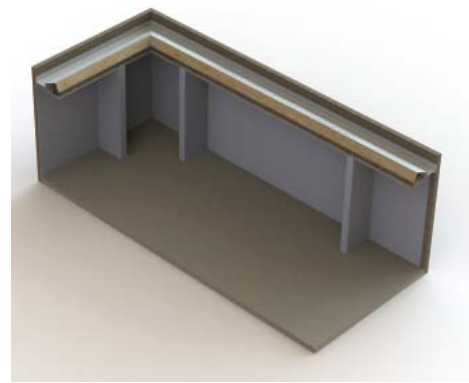

# INTRUSIONS

In some cases a roof may have to accommodate intrusions into the footprint of the roof, these are such things as chimney breasts. In this situation, the panel is adapted around the intrusion and a tapered box gutter is used. This creates many configurations of box gutters that allow water to drain away effectively.

## INTRUSION TAPERED BOX GUTTER

The panel is always supported by a wall mounted angle bracket that runs along the length of the intrusion. This instance does not require any additional structural support.

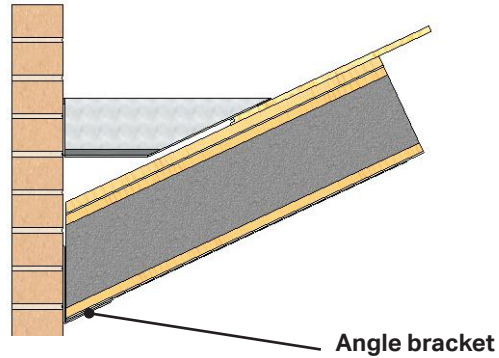

## MINIMUM INTRUSION SIZES

The tapered box gutter above the intrusion panel will always follow the tapered box gutter rules. However where the tapered box gutter meets the box beam, there are many variables to consider.

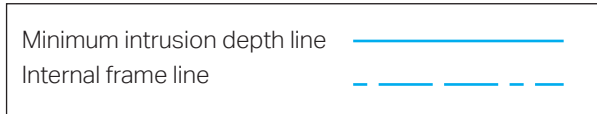

**A** Intrusion standard

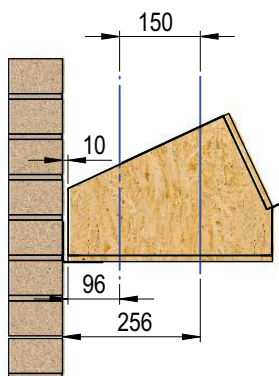

**B** Intrusion extended

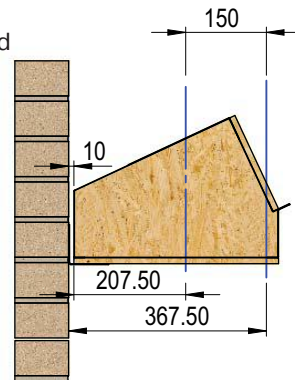

**C** 265 standard intrusions

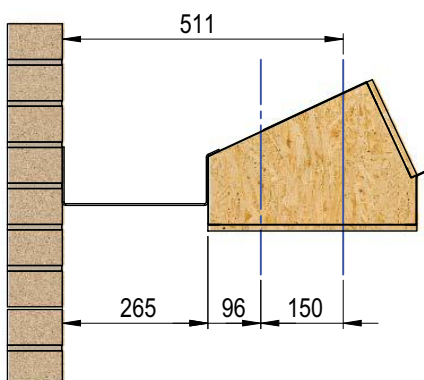

**D** 265 extended intrusion

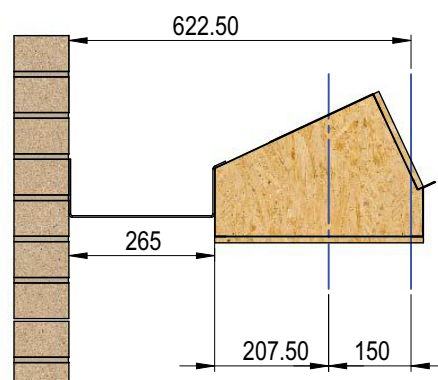

NOTE: to be read in conjunction with page 58

# INTRUSIONS

There are options for what kind of box gutter the tapered box gutter on the intrusion will run into, these follow the minimum intrusion size rules (see page 57).

TAPERED JOINING STANDARD

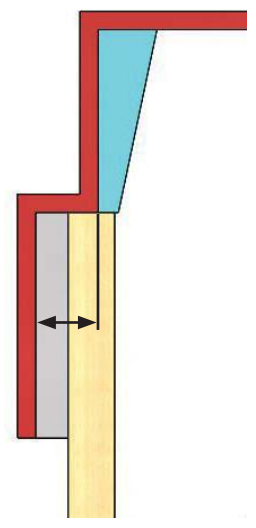
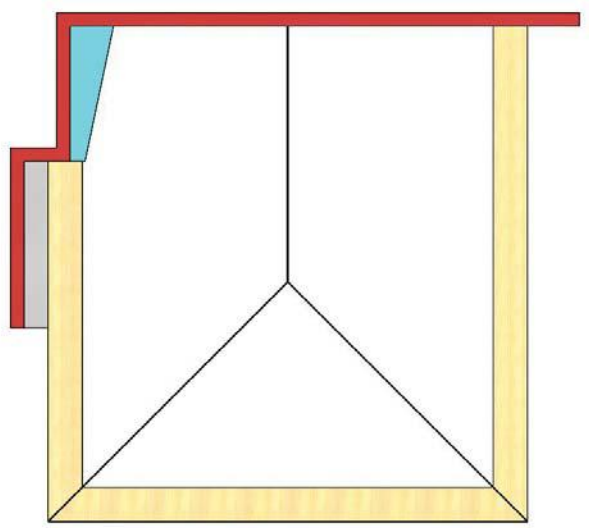

- C 511mm MIN INTRUSION**
- D 622.5mm EXTENDED SOFFIT WITH INTRUSION MIN**

TAPERED JOINING TAPERED

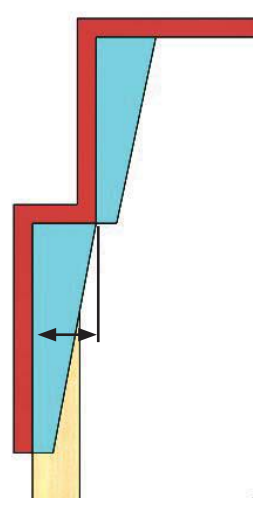
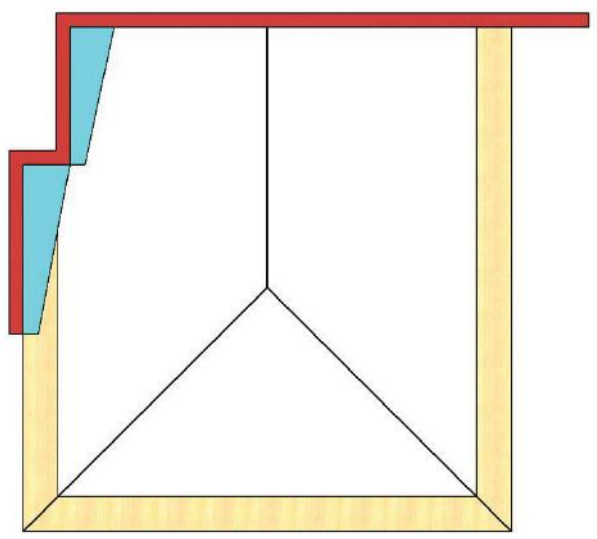

- A 256mm MIN INTRUSION**
- B 367.5mm EXTENDED SOFFIT WITH INTRUSION MIN**

<b>KEY</b>			
	HOST WALL		BEAMS
	TAPERED BOXGUTTER		BOXGUTTER

# CENTRAL INTRUSIONS

Examples following rules on page 57

TAPERED JOINING STANDARD

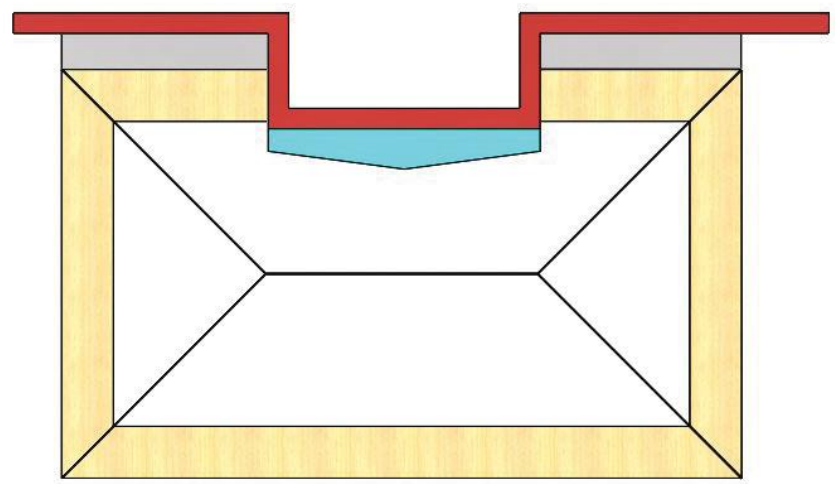

TAPERED JOINING TAPERED

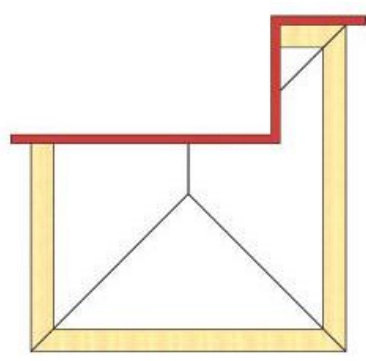
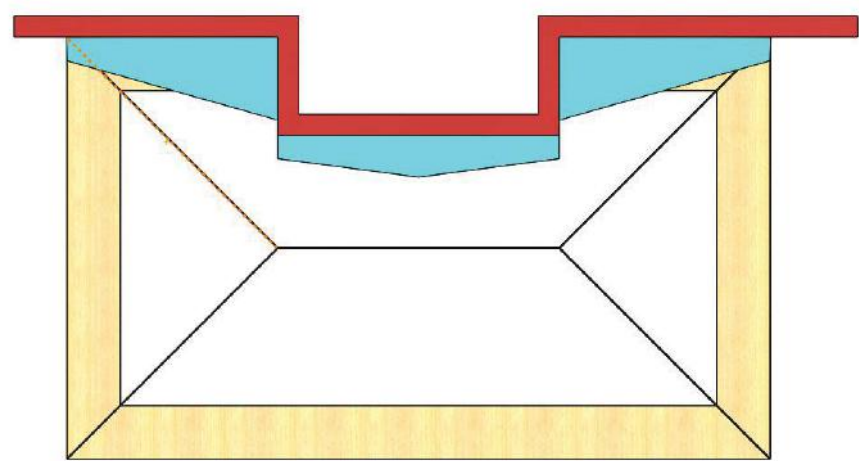

Double hipped georgian intrusion

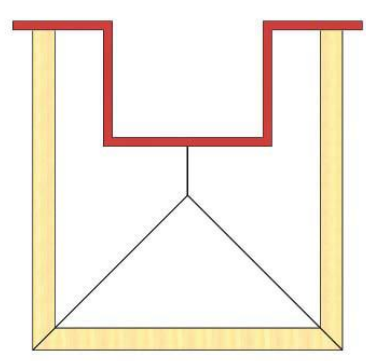



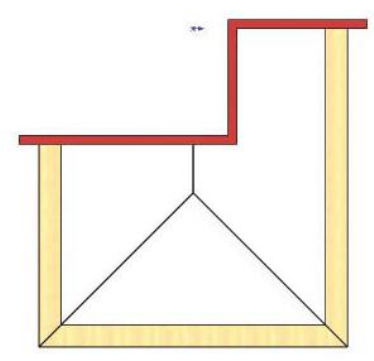

Georgian central intrusion



Georgian large intrusion

**KEY**

	HOST WALL		BEAMS		TAPERED BOXGUTTER		BOXGUTTER
---	-----------	---	-------	---	-------------------	---	-----------



DETAILED INTRUSION RULES

INTERNAL  
FRAME LINE

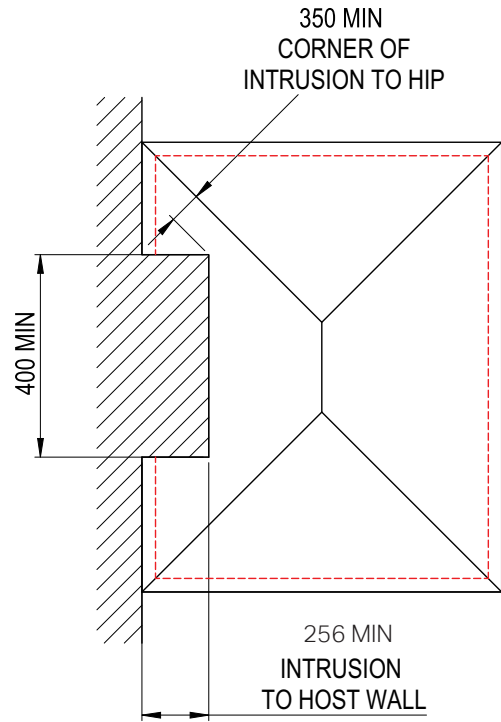
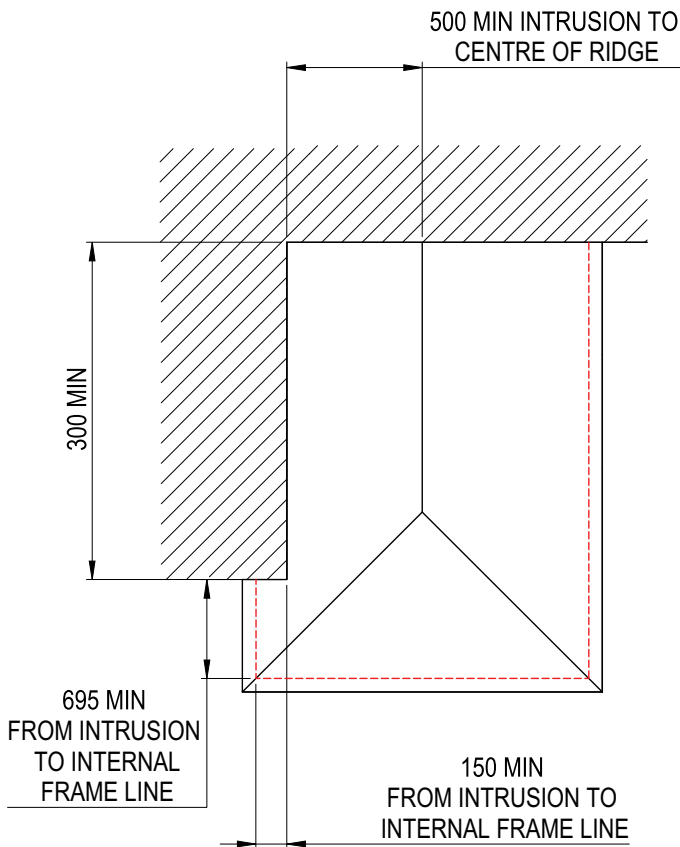

NO GLAZING ALLOWED IN  
ROOF SECTIONS WHERE  
THERE IS AN INTRUSION

ROOF LIGHTS ARE  
PERMITTED ONLY ON  
OTHER SIDE OF RIDGE  
FROM INTRUSION

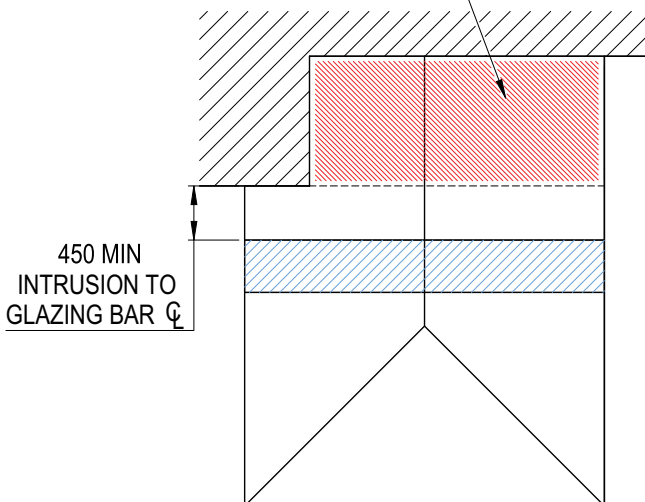

DETAILED INTRUSION RULES

INTERNAL FRAME LINE

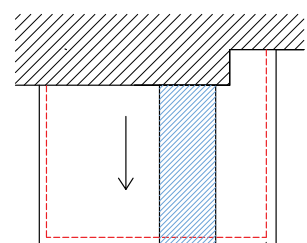
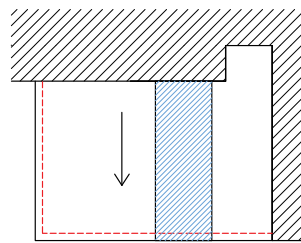
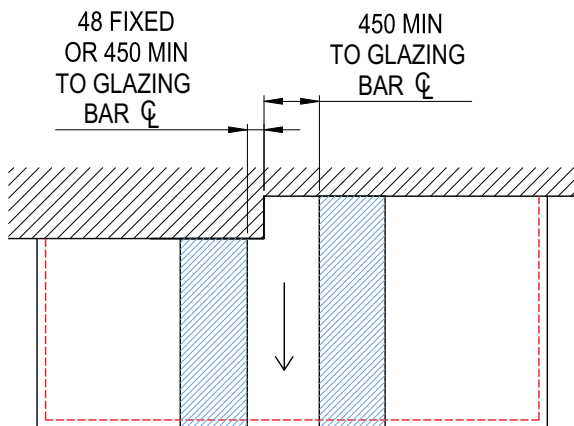
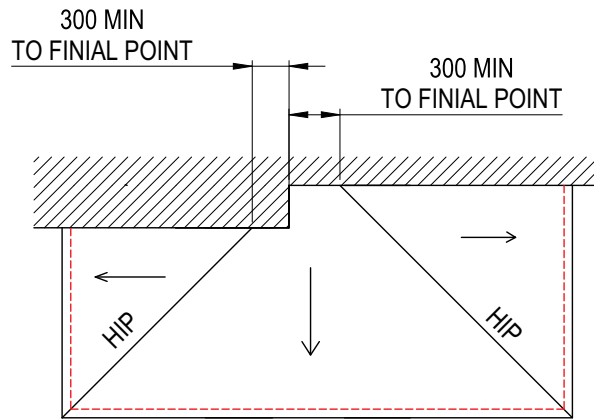
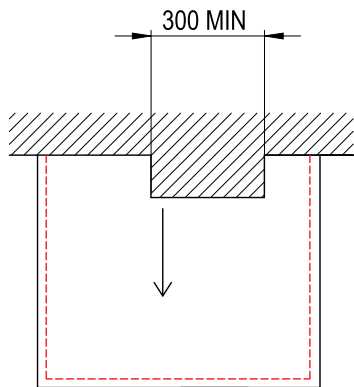
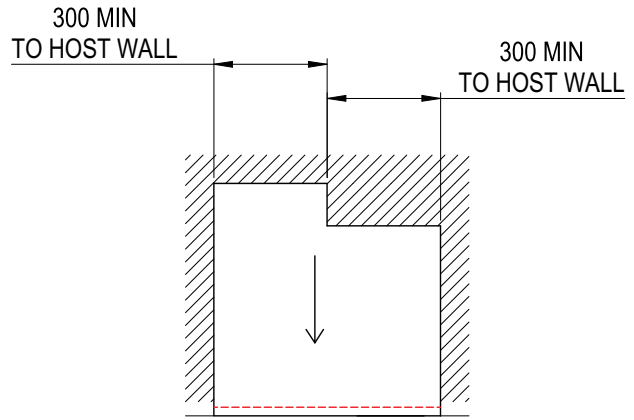
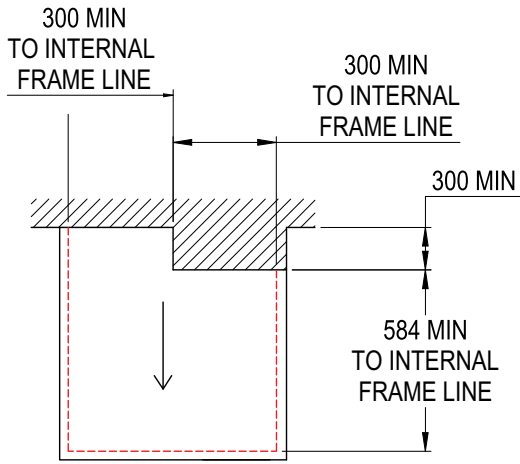

450 MIN

450 MIN

# BOX BEAM ON WINDOW FRAME

The following examples show the box beam on new or existing window frames.

## STANDARD SOFFIT

A

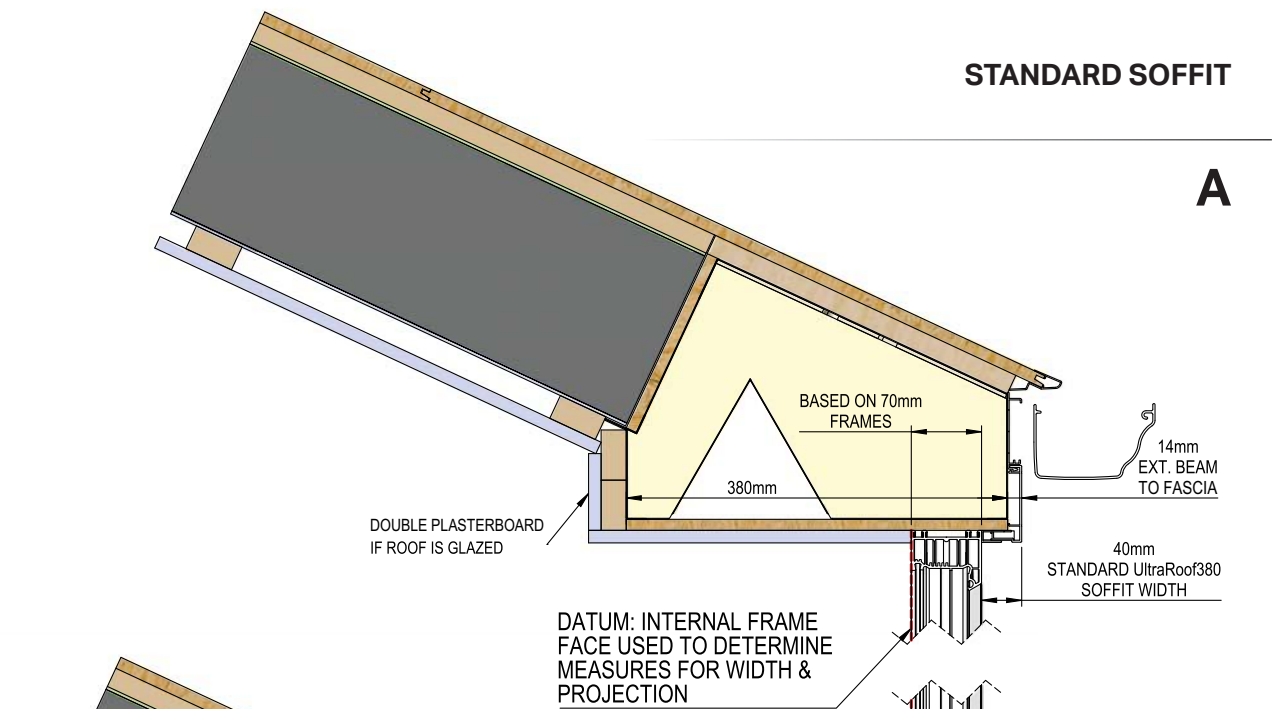

## EXTENDED SOFFIT

B

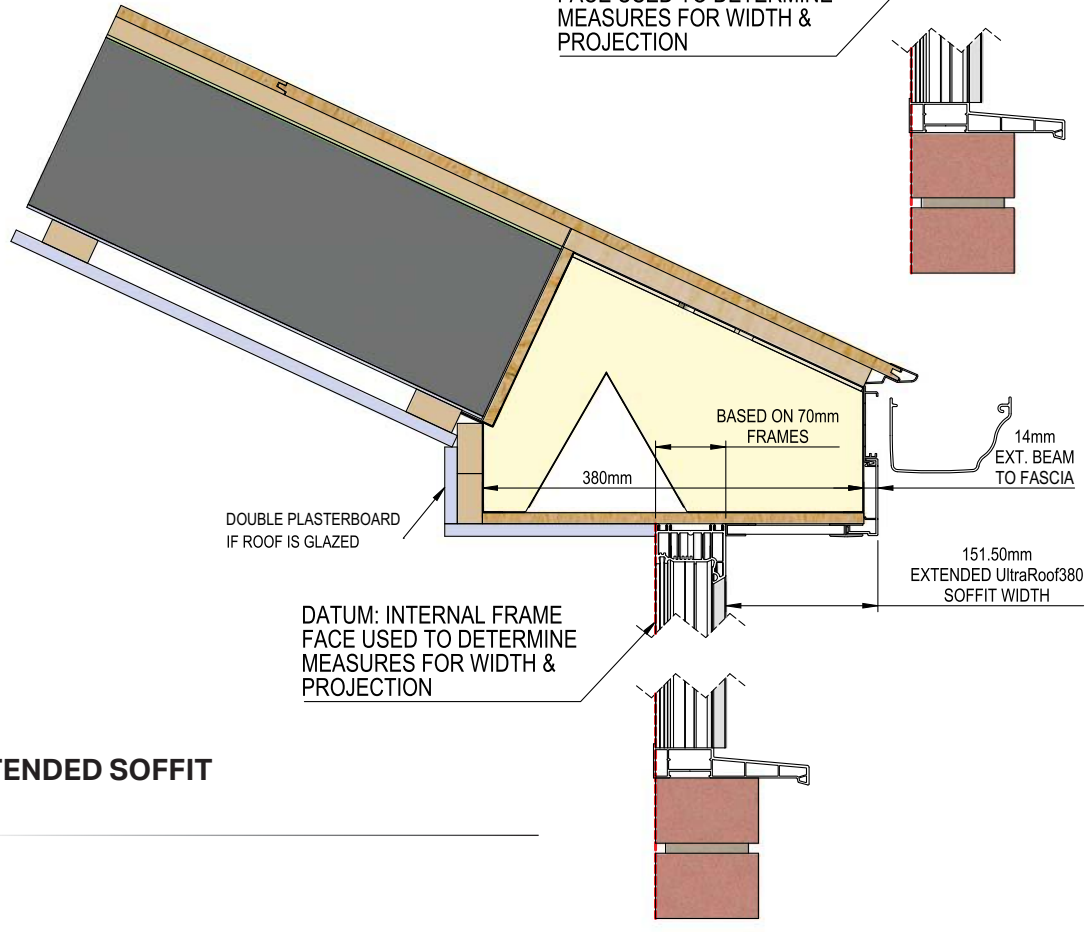

## BOX BEAM ON BRICK WORK

Below is shown the details for fixing a box beam to the top of solid brick work with associated soffit depths.

### OPTION 1

ALIGNING BOX BEAM WITH INTERNAL BLOCK FACE

FOR THIS BRICKWORK OPTION - SPECIFY ROOF AS 'EXTENDED SOFFIT' AND DECREASE SIZE OF ROOF BY 25mm (PER SIDE)

NOTE: DO NOT ALTER PROJECTION AT GABLE.

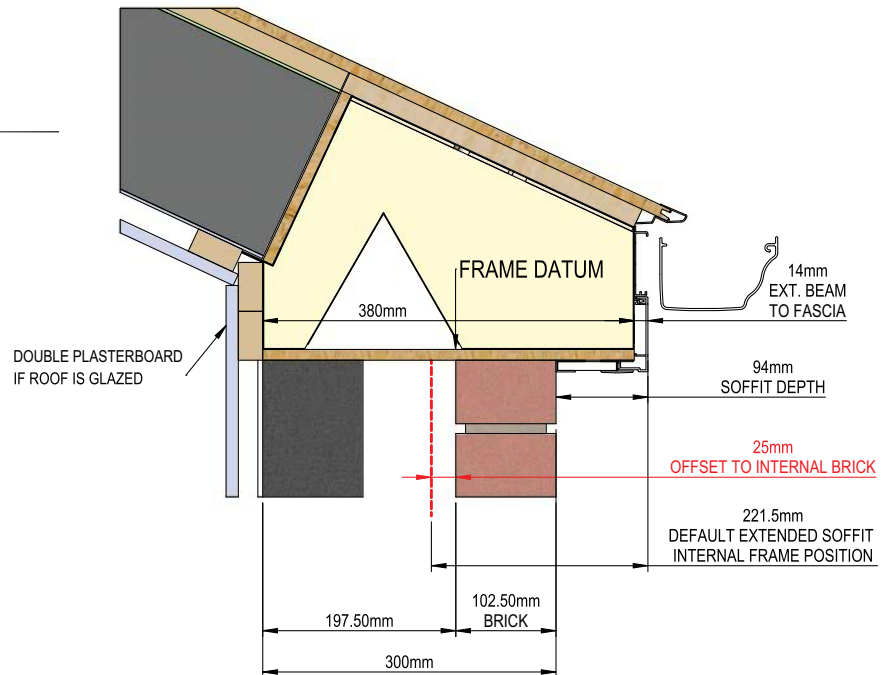

### OPTION 2

MAINTAINING INTERNAL SOFFIT WIDTH WHEN SAT ON BRICK WALL

FOR THIS BRICKWORK OPTION - SPECIFY ROOF AS 'STANDARD SOFFIT' AND DECREASE SIZE OF ROOF BY 197.5mm (PER SIDE)

NOTE: DECREASE GABLE PROJECTION OF ROOF (WHERE APPLICABLE) BY 200mm.

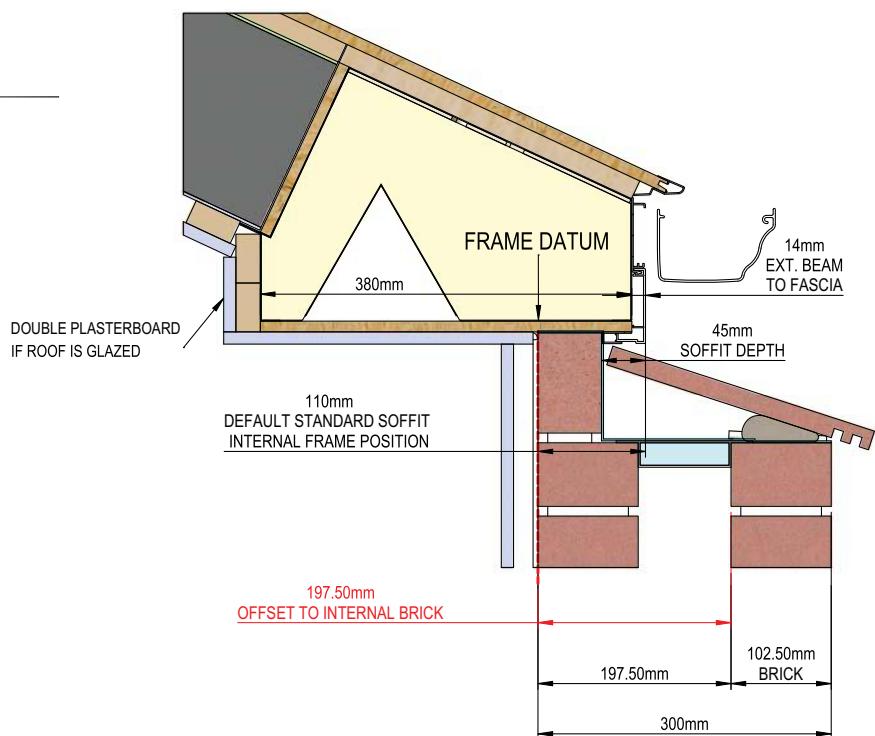

Please Note: All illustrations shown assume a 300mm cavity wall and 70mm window frames. These dimensions may need to be modified to suit your on-site conditions

## BOX BEAM ON BRICK AND WINDOW FRAME

Some situations will have a mix of window frames and brickwork that will support the length of the box beam. Below shows the details for fixing a box beam to the top of window frames with brick work.

### OPTION 3

IF MAINTAINING THE STANDARD SETOUT WHEN SAT ON A BRICK WALL A CILL MUST BE INCLUDED

FOR THIS BRICKWORK OPTION - SPECIFY ROOF AS 'STANDARD SOFFIT' - NO NEED TO MODIFY SIZE.

NOTE: DO NOT ALTER PROJECTION AT GABLE.

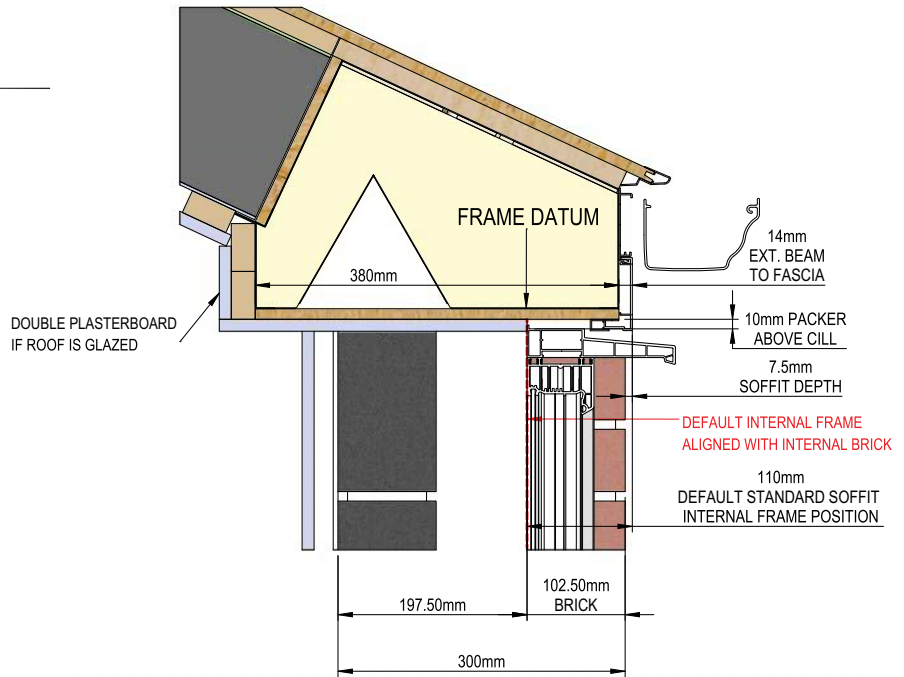

### OPTION 4

ALIGNING 40mm SOFFIT WITH EXTERNAL BRICK FACE

FOR THIS BRICKWORK OPTION - SPECIFY ROOF AS 'EXTENDED SOFFIT' AND DECREASE SIZE OF ROOF BY 79mm (PER SIDE)

NOTE: DO NOT ALTER PROJECTION AT GABLE.

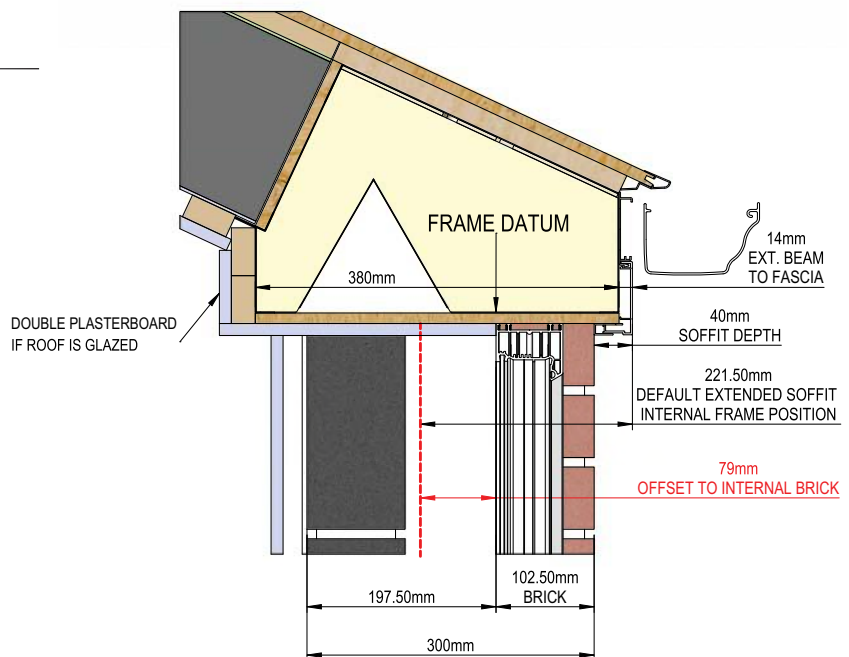

Please Note: All illustrations shown assume a 300mm cavity wall and 70mm window frames. These dimensions may need to be modified to suit your on-site conditions

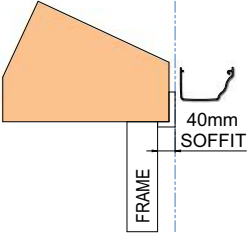
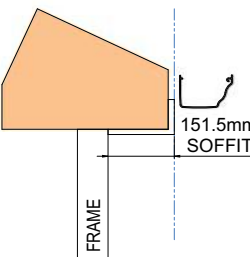
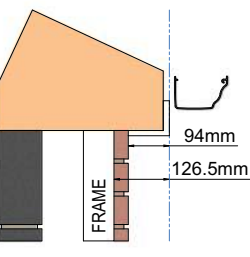
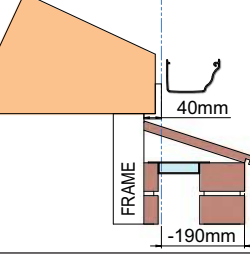
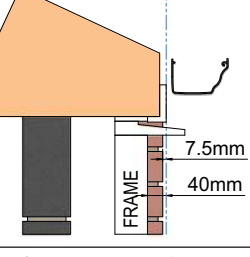
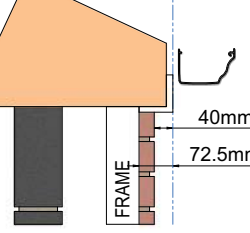

		SOFFIT WIDTHS		U-DESIGN ORDERING TIP	
		Soffit Relative to EXTERNAL BRICK (300mm Cavity wall)	SOFFIT RELATIVE TO EXTERNAL FRAME (70MM FRAMES)	Specify Soffit Type	Dimensional Adjustment PER SIDE (minus)
Standard Soffit on frames		N/A	40mm	STANDARD	N/A
Extended Soffit on frames		N/A	151.5mm	EXTENDED	N/A
Brick Option 1		94mm	126.5mm	EXTENDED	-25mm (minus)
Brick Option 2		-190mm	40mm	STANDARD	-197.5mm (minus)
Brick Option 3		7.5mm	40mm	STANDARD	0mm
Brick Option 4		40mm	72.5mm	EXTENDED	-79mm (minus)

Please Note: All illustrations shown assume a 300mm cavity wall and 70mm window frames. These dimensions may need to be modified to suit your on-site conditions

# SOFFIT RELATIVE TO EXTERNAL FRAME

## OPTION 1

---

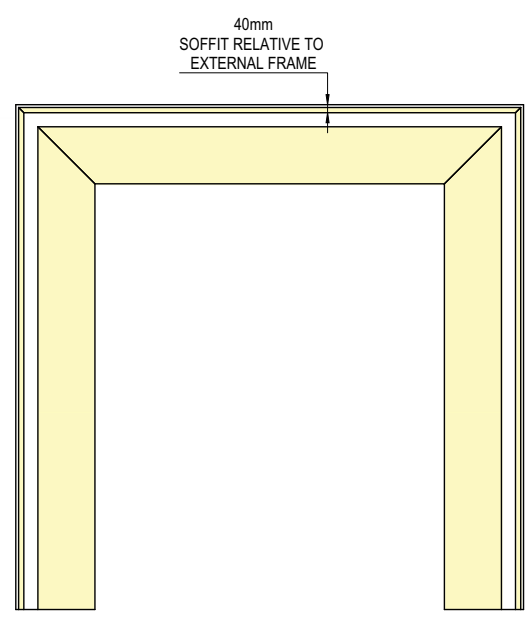

## OPTION 2

---

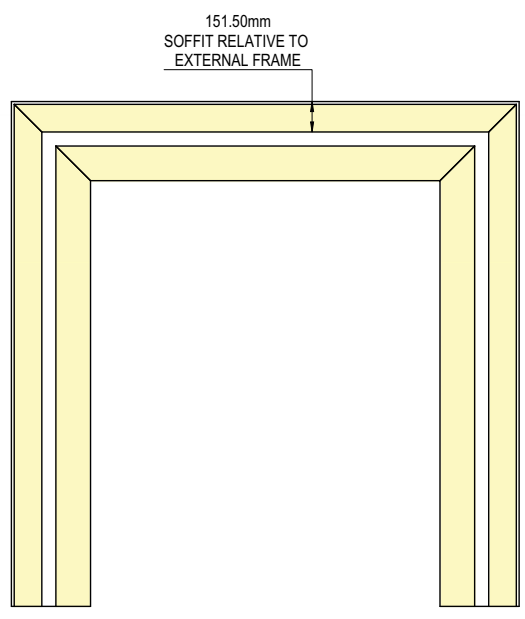

# SOFFIT RELATIVE TO EXTERNAL BRICK

**OPTION 1**

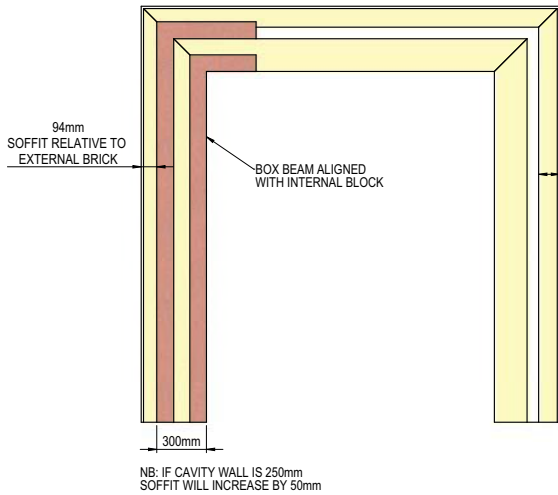

**OPTION 2**

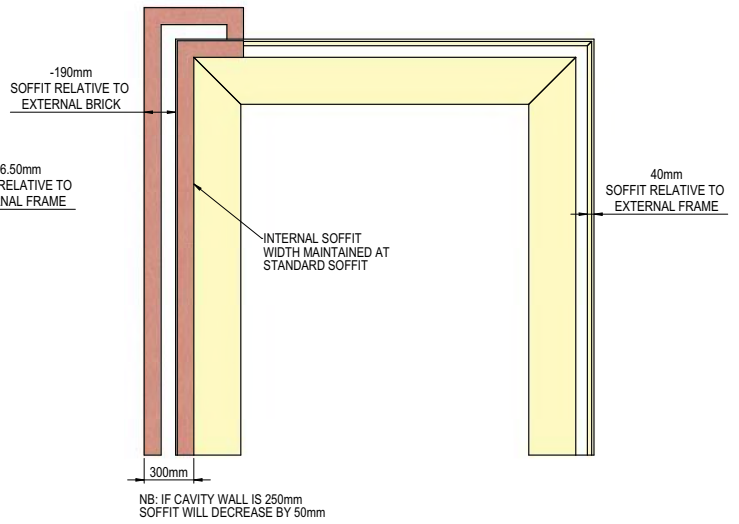

**OPTION 3**

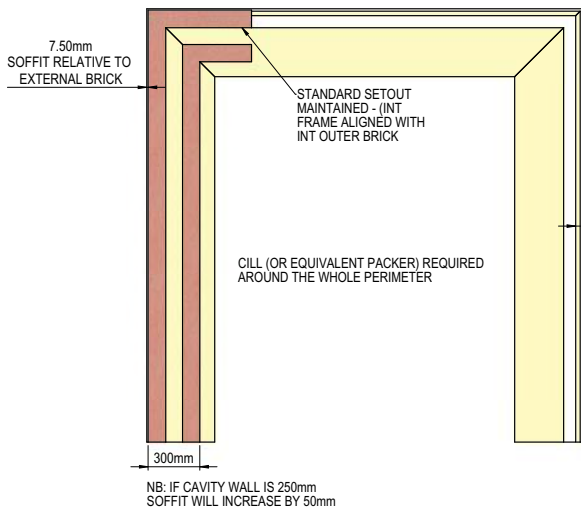

**OPTION 4**

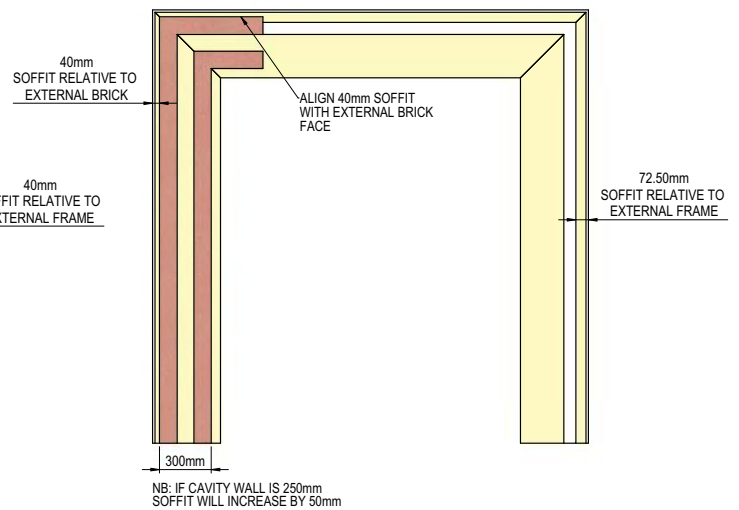

### JOINING TWO BEAMS

When a roof length extends further than 7000mm, then two beams must be joined. The way the two box beams join is shown below.

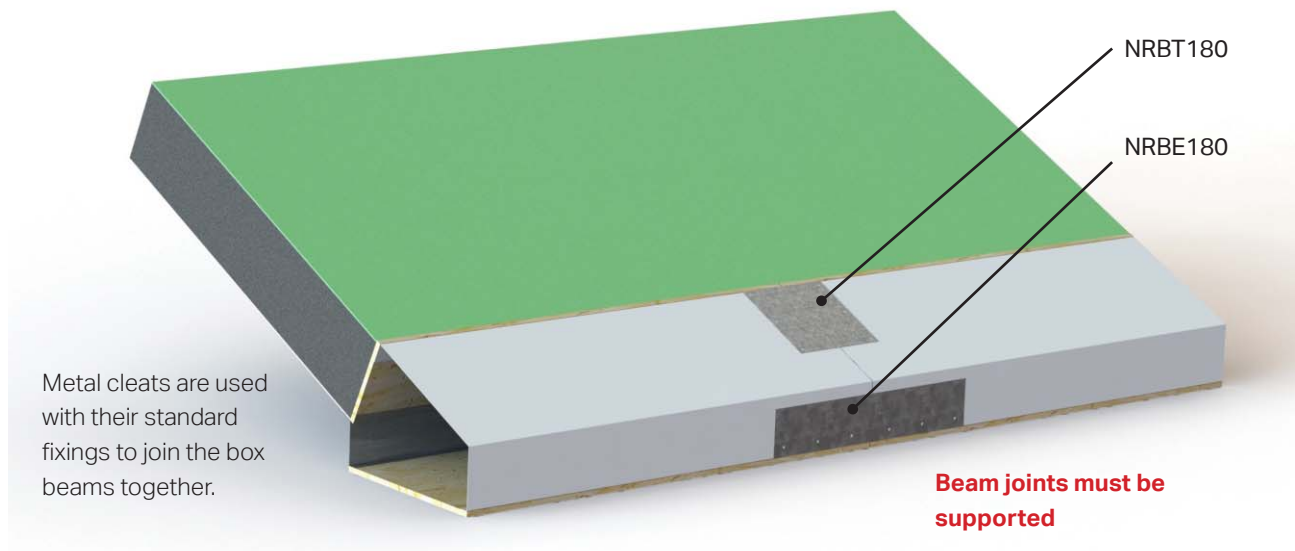

### SUPPORTING JOINT ON BRICK

When two beams need to be joined they need to be supported, one option is a brick pillar. The pillar can be built as shown below.

Standard soffit

Extended soffit



## JOINING TWO BEAMS

Before the beam is placed on the brick pillar they must be connected together with a flat abutment bracket that spans the two beams. Use the fixings provided to secure the plate in place as the plate will be inaccessible when the beam is in position over the brick pillar.  
NOTE: this is only used when a beam is joined on a brick pillar.

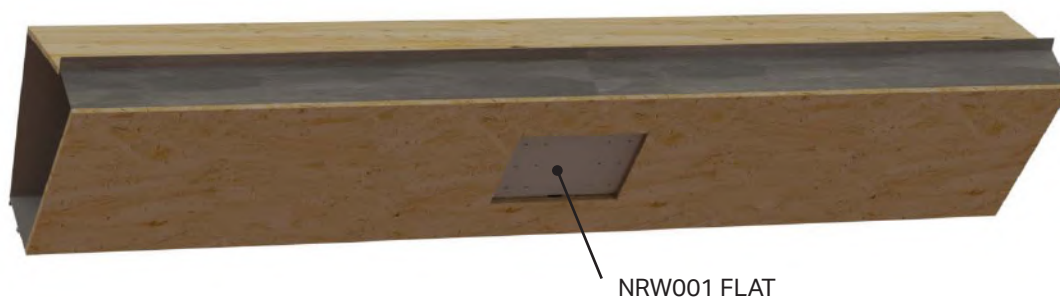

### Standard soffit shown

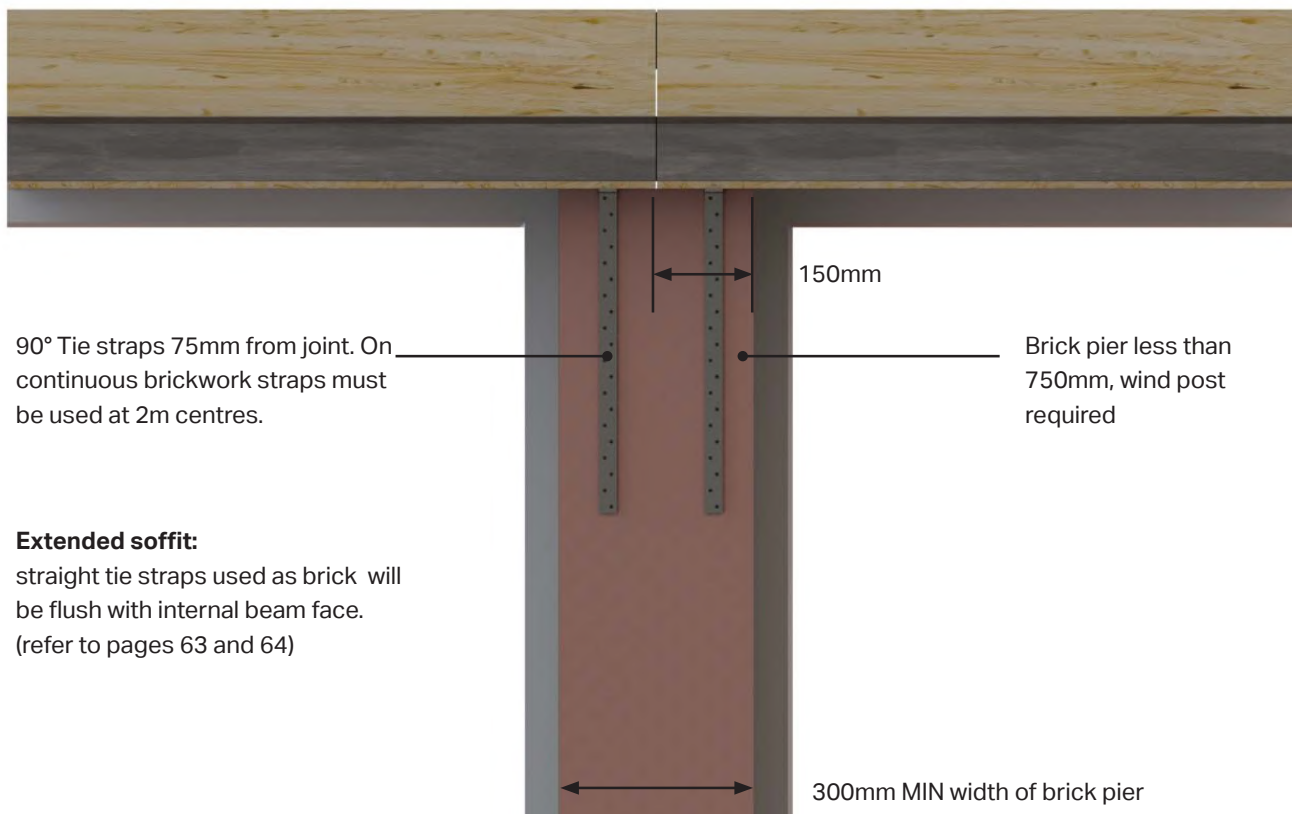

## RULES

- The minimum size for the brick pillar is 300mm wide (wind post required).
- The join must be minimum 150mm from the brick external face.
- Brick pillar width less than 750mm in width, a wind post is required.



## INTERNAL BRICK BEAM JOINT

When a beam joint occurs along an existing wall, a brick pier can be used to support the beam from below. The pier can be built up to the existing wall or can be left self standing, below shows the situations this occurs.

265 box gutter situation

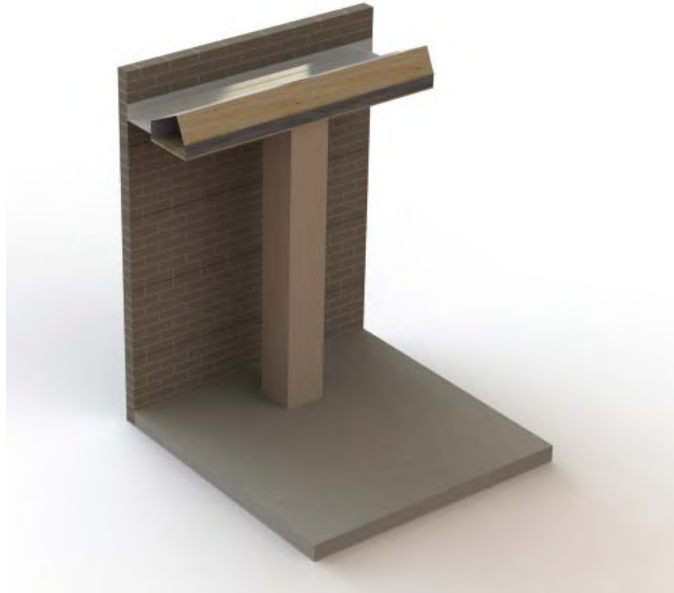

Tapered box gutter situation

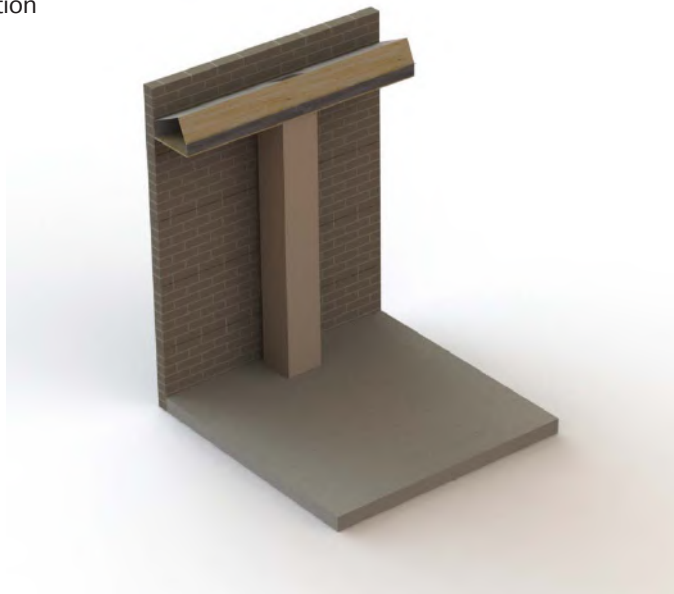

### RULES

- The minimum size for the brick pillar is 240mm x 300mm.
- The joint must be minimum 150mm from the brick external face on the pillar.
- Pillar can be left free standing or built back to the host wall.

## SUPPORTING JOINT ON POST

An alternative way of supporting a beam joint is the use of an aluminium support post placed under the beam joint. The post is cut into the existing brick work (if necessary) and fixed to the concrete floor. A plate on top of the beam connects the two beams together. The plate sits in the cut out position of where the abutment bracket would sit.

NOTE: first beams are joined on the post fixing plate then metal cleats are added later.

Standard soffit



Extended soffit



## BOX GUTTER FOAM

### (BGI072)

The cavity wall brick must be cut to allow the post to sit 10mm from the external brick, this is packed off with box gutter foam to create a thermal break. A bigger void at the base must be cut into the wall to allow access to the fixings at the base of the post

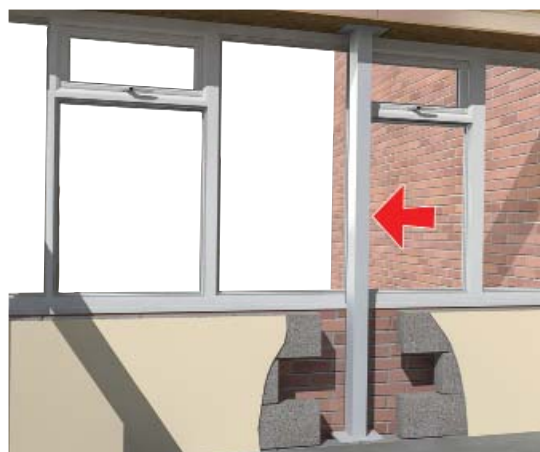

## INTERNAL JOINT ON POST

When a beam joint occurs along an existing wall, a post can be used to support the beam from below. (Also refer to page 73).

265 box gutter situation

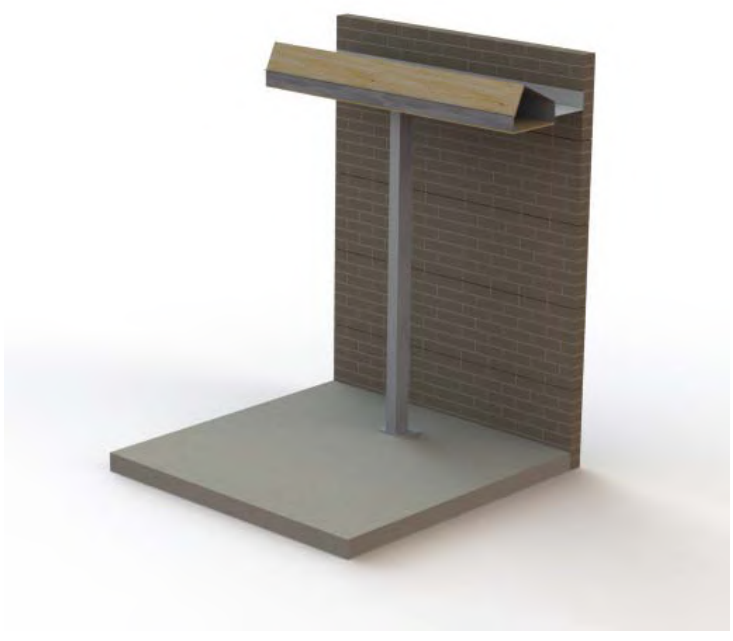

Tapered box gutter situation

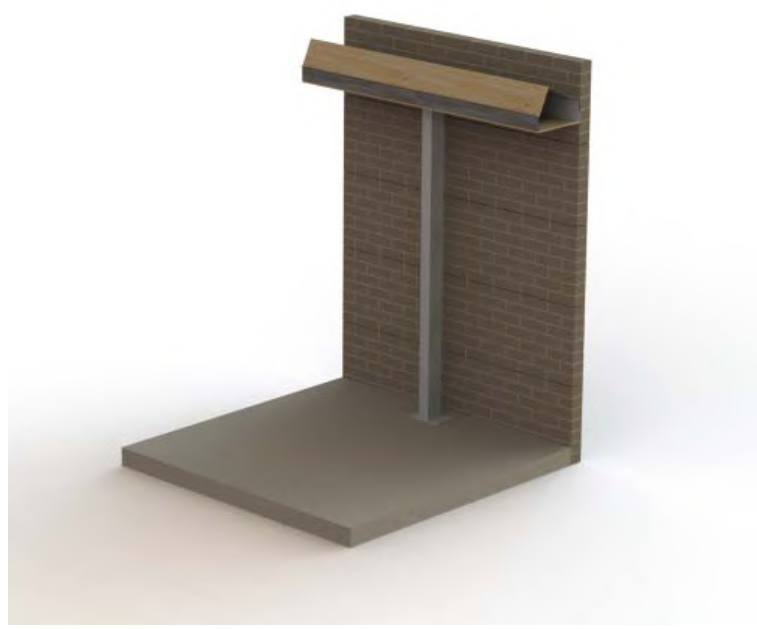

### RULES

- Post must sit in abutment bracket cut out position, the bracket cut out is pre cut depending on the type of box gutter required on the beam.

## FIXING PLATE

The beams are fixed to the post using the fixing plate with the same footprint as an abutment bracket. The metal cleats are then fixed after the beams are fixed to the post. The post position in relation to the beam will vary depending on the soffit size.



Standard soffit



Extended soffit



## RULES

- Post must sit in abutment bracket cut out position, the bracket cut out is pre cut depending on the type soffit on the beam.

# BOX BEAM ON LOGGIA COLUMN

If your installation contains a loggia column, then it is possible to support the box beam on the column providing that the beam is installed with the following details.

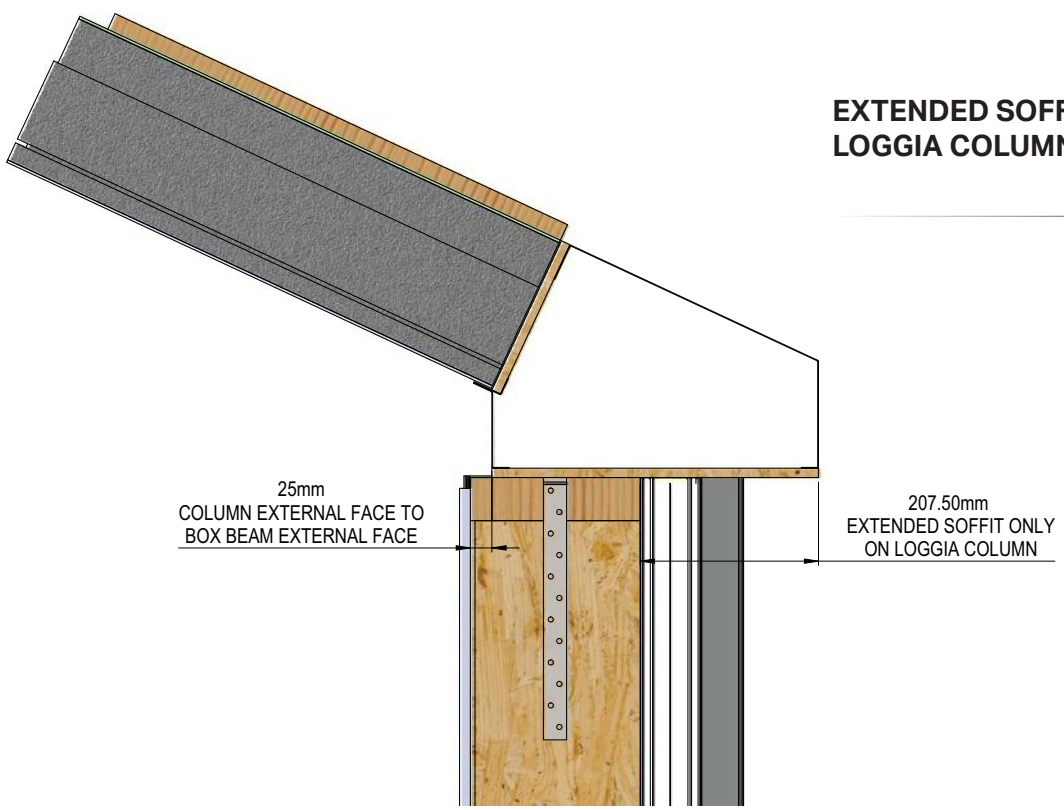



# GEORGIAN ROOF ON A VICTORIAN FRAME - TUDOR



Before



After

It is possible to fit an UltraRoof380 Georgian shape to the top of an existing Victorian conservatory frame. Maximum cantilever 1,200mm from corner.

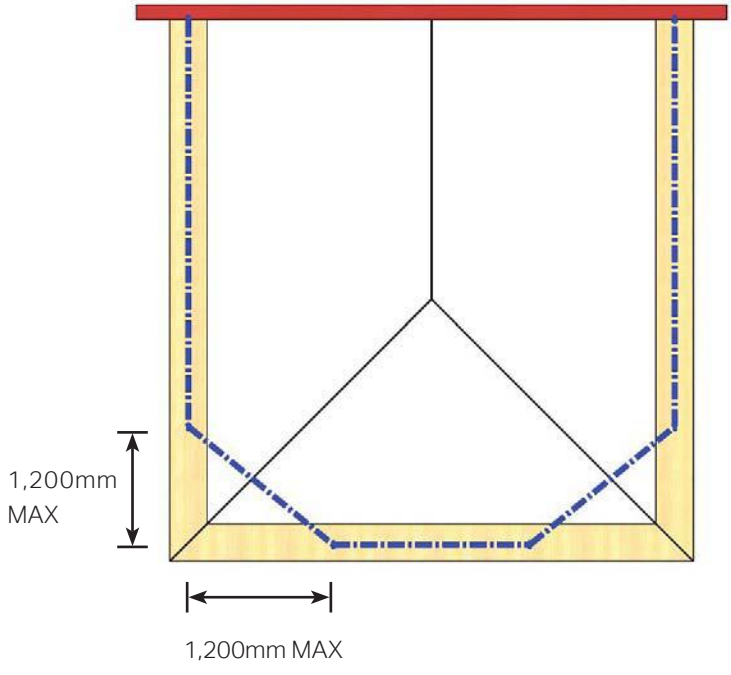

tudor Conservatory Frame      - - - - -

# OUT OF SQUARE - WINDOW FRAMES/MASONRY SUPPORTS

Out of square roofs must be specified with extended soffits only. The external soffit will vary in width. This must be agreed with the customer.

Below shows the example of frames out of square by 50mm (i.e. visual difference in soffit width of 100mm). The internal pelmet width will also vary.

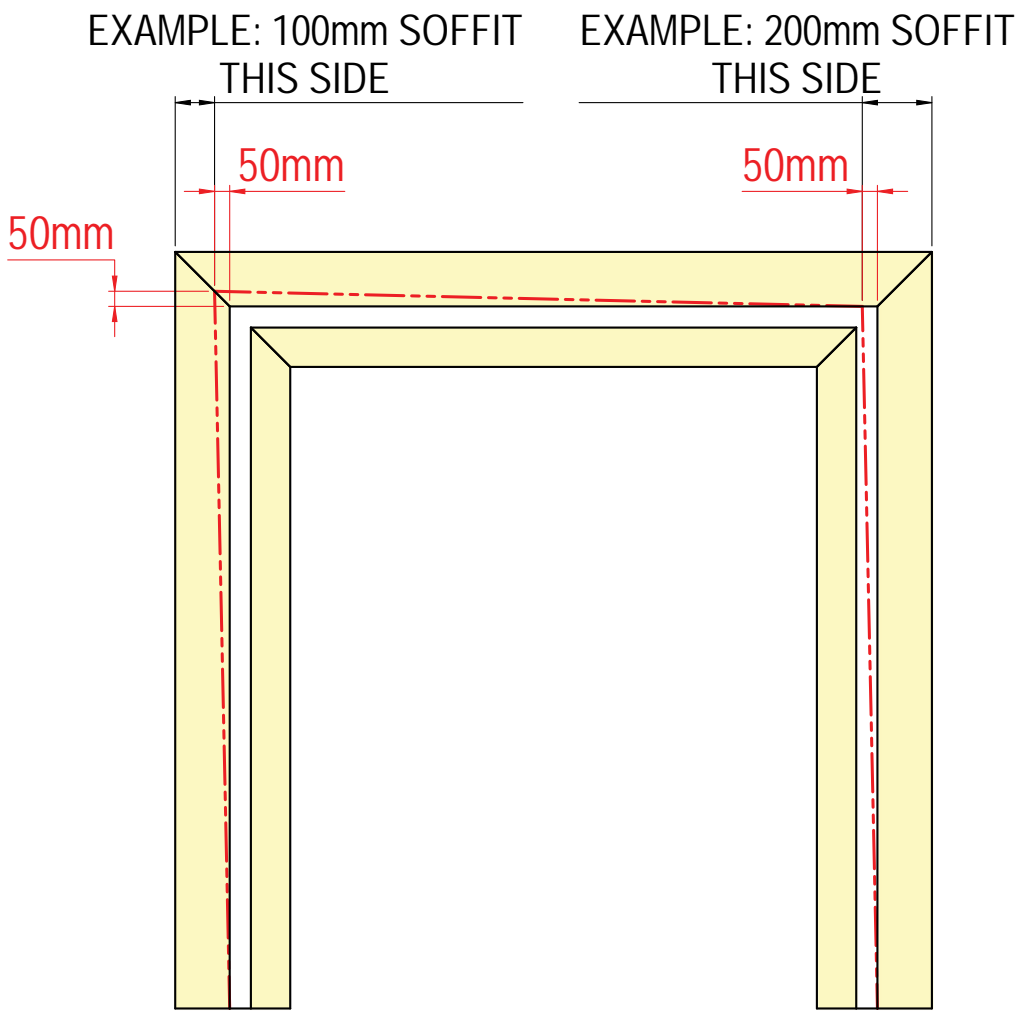

# CONVERTING EXISTING CONSERVATORY WITH BOXGUTTER TO ULTRAROOF380

When converting an existing conservatory to an UltraRoof 380, it is important to accommodate for the previous box gutter positions on the conservatory roof when designing the UltraRoof replacement. When the old conservatory box gutter is removed, (either a 165 or a 265), the beam sits on the existing window frames lining up with the internal frame line datum points. This results in a special finishing detail for each case being used, as shown below.

Existing conservatory with inner dwarf wall built in-line with host wall.

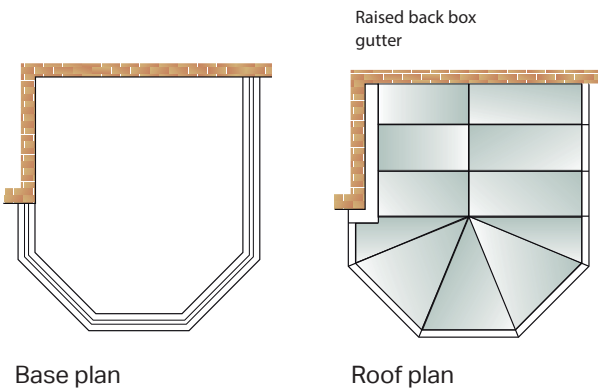

## STANDARD SOFFIT

## EXTENDED SOFFIT

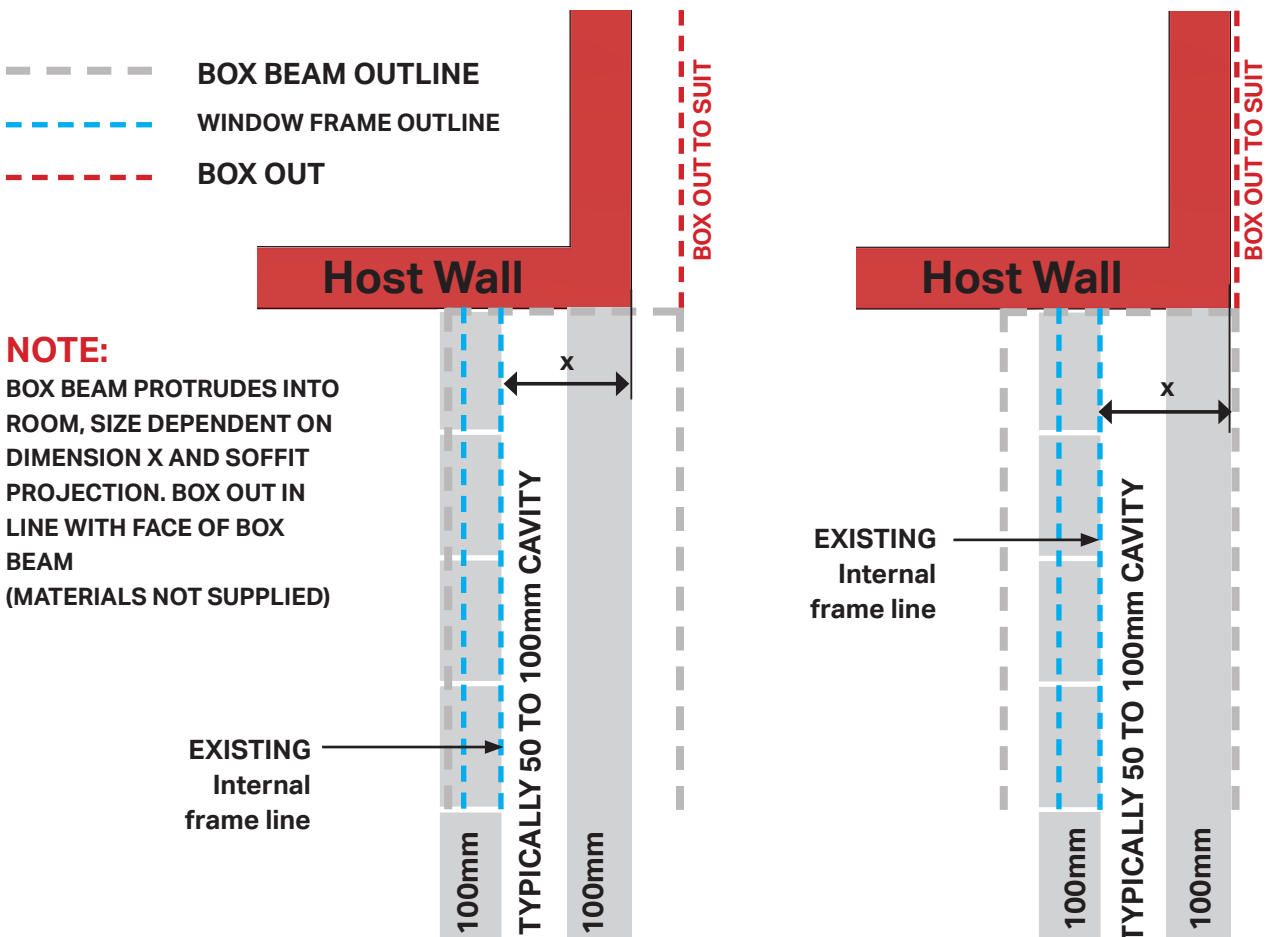

**STANDARD SOFFIT BOXING OUT**

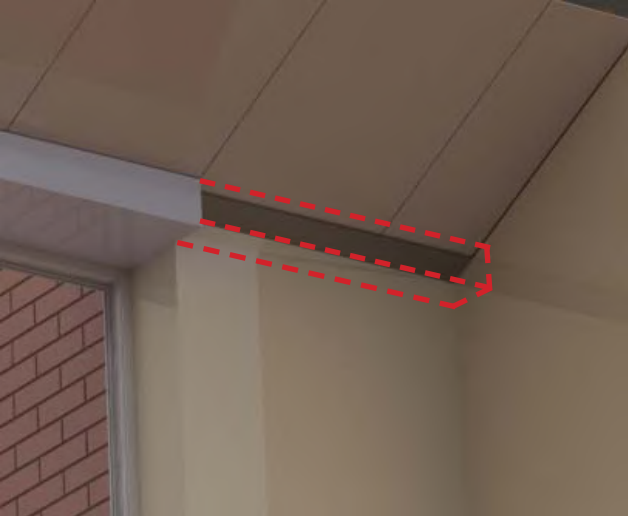

**BOX OUT TO SUIT  
(MATERIALS NOT SUPPLIED)**

**EXTENDED SOFFIT BOXING OUT**

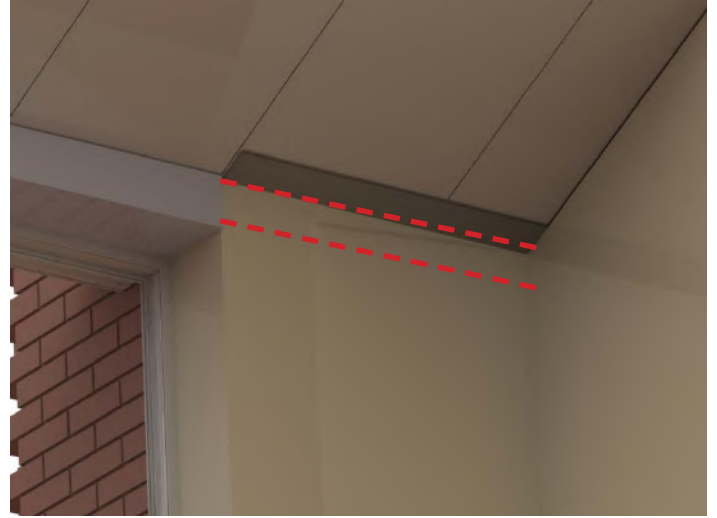

**BOX OUT TO SUIT  
(MATERIALS NOT SUPPLIED)**

**STANDARD SOFFIT**

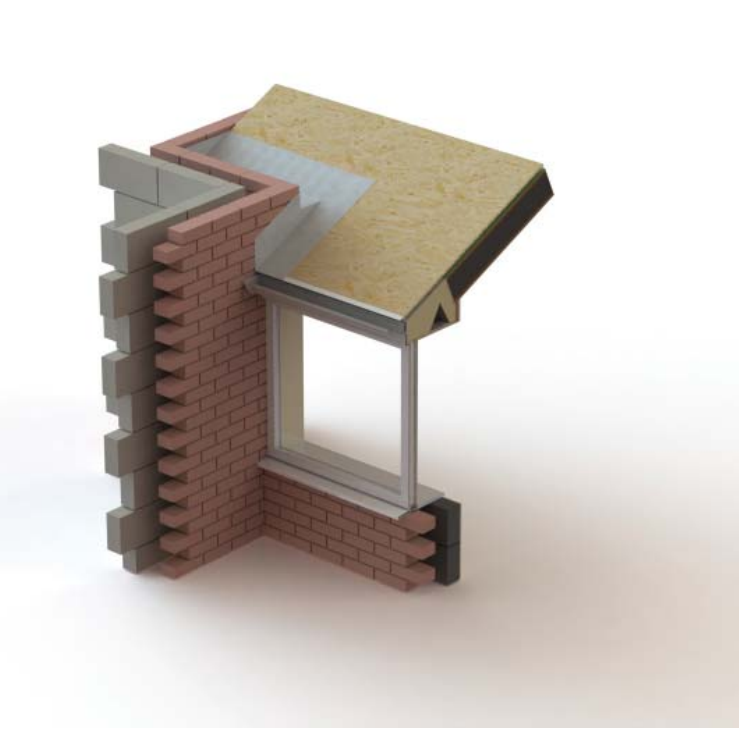

**EXTENDED SOFFIT**

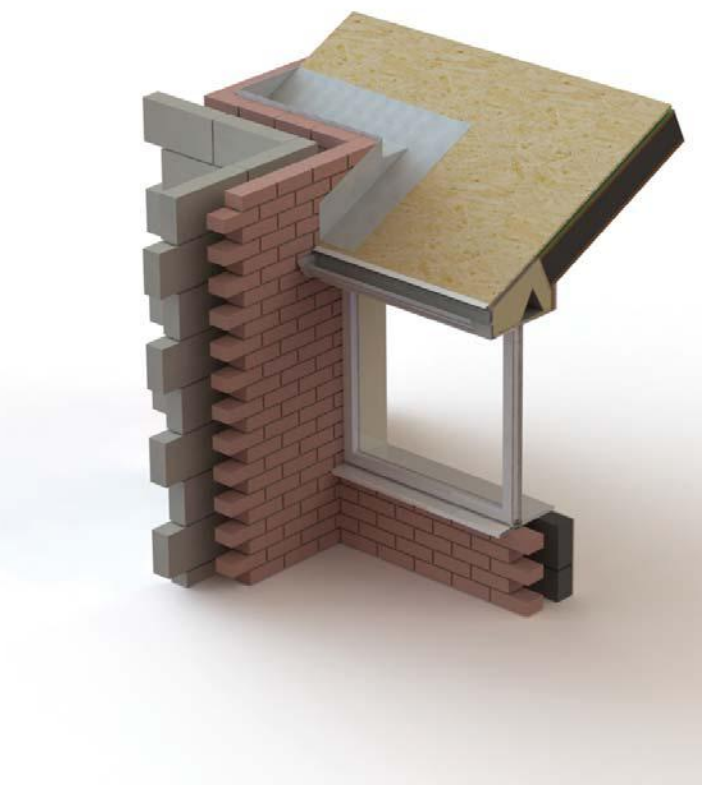

# CONVERTING EXISTING CONSERVATORY WITH BOXGUTTER TO ULTRAROOF380

Existing in-line 165 boxgutter

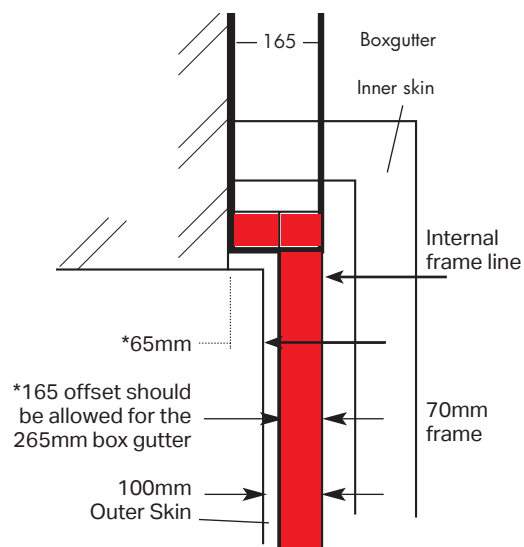
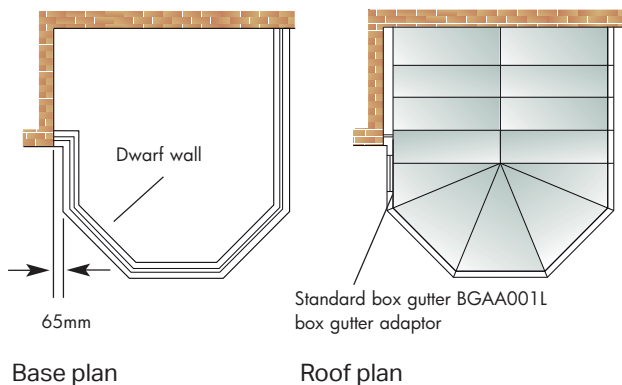

## 165 BOX GUTTER REPLACEMENT

**Standard soffit:** The internal frame line will be 165mm from the host wall, this will result in a gap of 69mm down the side of the beam. This gap is packed out with timber at 59mm and 10mm of box gutter insulation. The beam is supported on the wall with abutment bracket and to existing conservatory window frames. A tapered box gutter is added packed 59mm off the host wall.

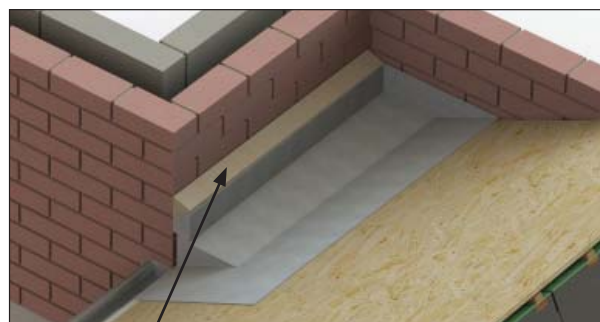
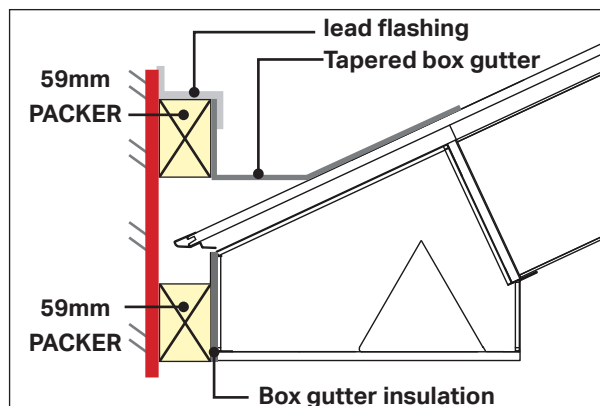

59mm timber packer, lead flash over into tapered box gutter.

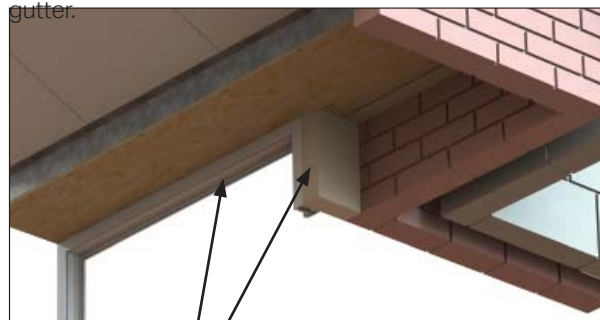

Existing frames and infill

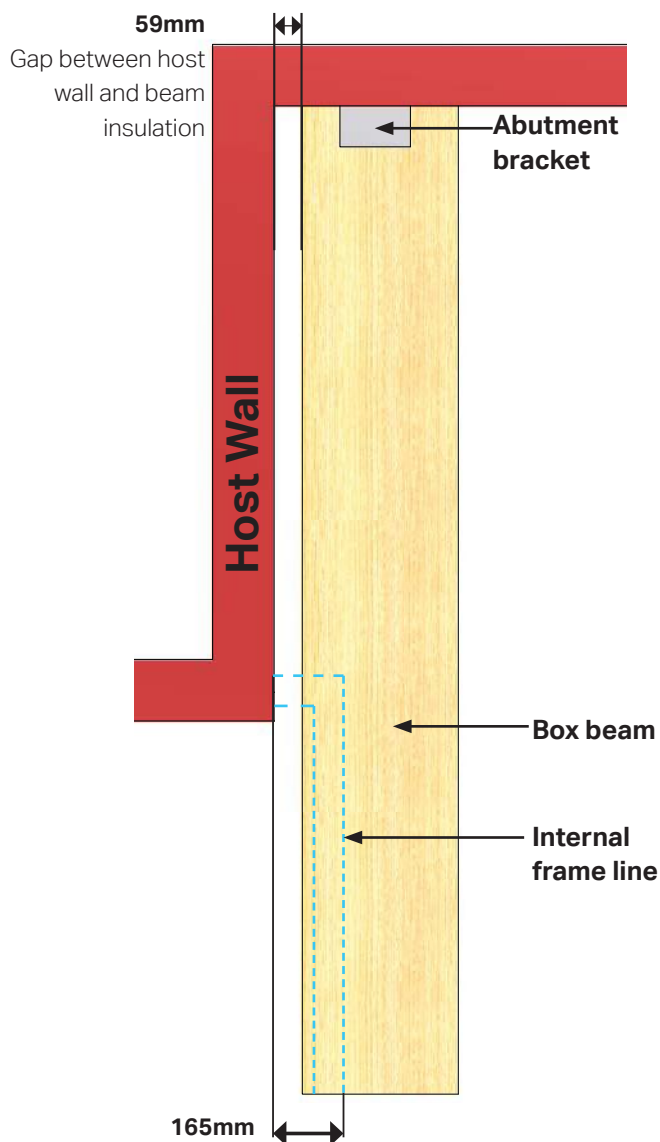



**Extended soffit:** The internal frame line will be 165mm from the host wall, this will result in the beam overshooting the wall by 42.5mm. The beam is stopped at the point of contact with the wall and an intrusion panel is used along the rest of the length. The beam is supported with an abutment bracket fixed to a timber infill while the panel is supported with an angled panel wall bracket (see diagram below). The intrusion must be cut on site to accommodate the timber infill square to the wall.

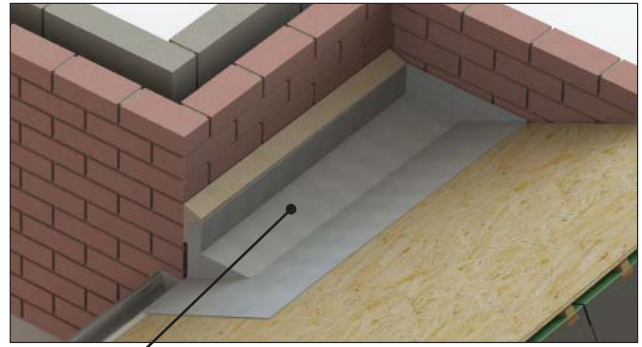

A tapered box gutter is used in this situation, it fits normally and flush with the host wall and roof.

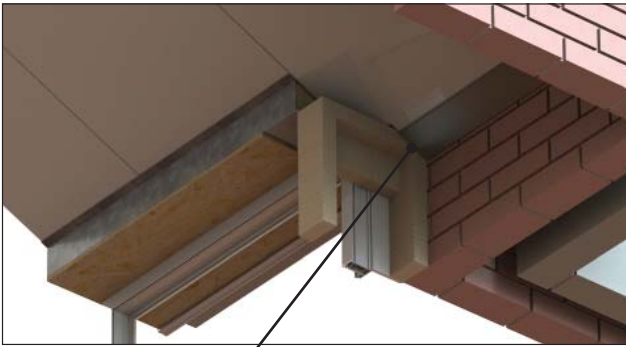

Infill 95 x 337.5mm In this case infill option is shown as timber. Intrusion panel is cut to accommodate the infill



**Abutment bracket** is fixed to the infill timbers, angled panel bracket fixes to the wall.

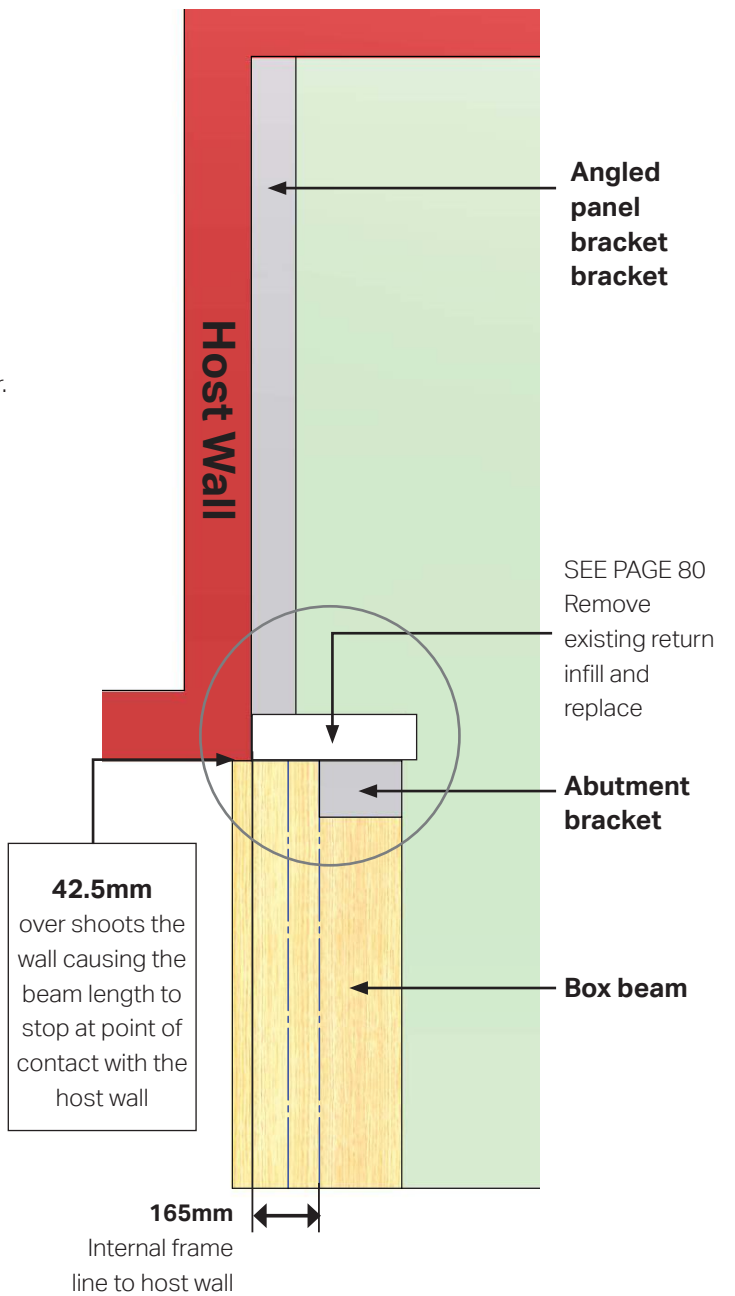

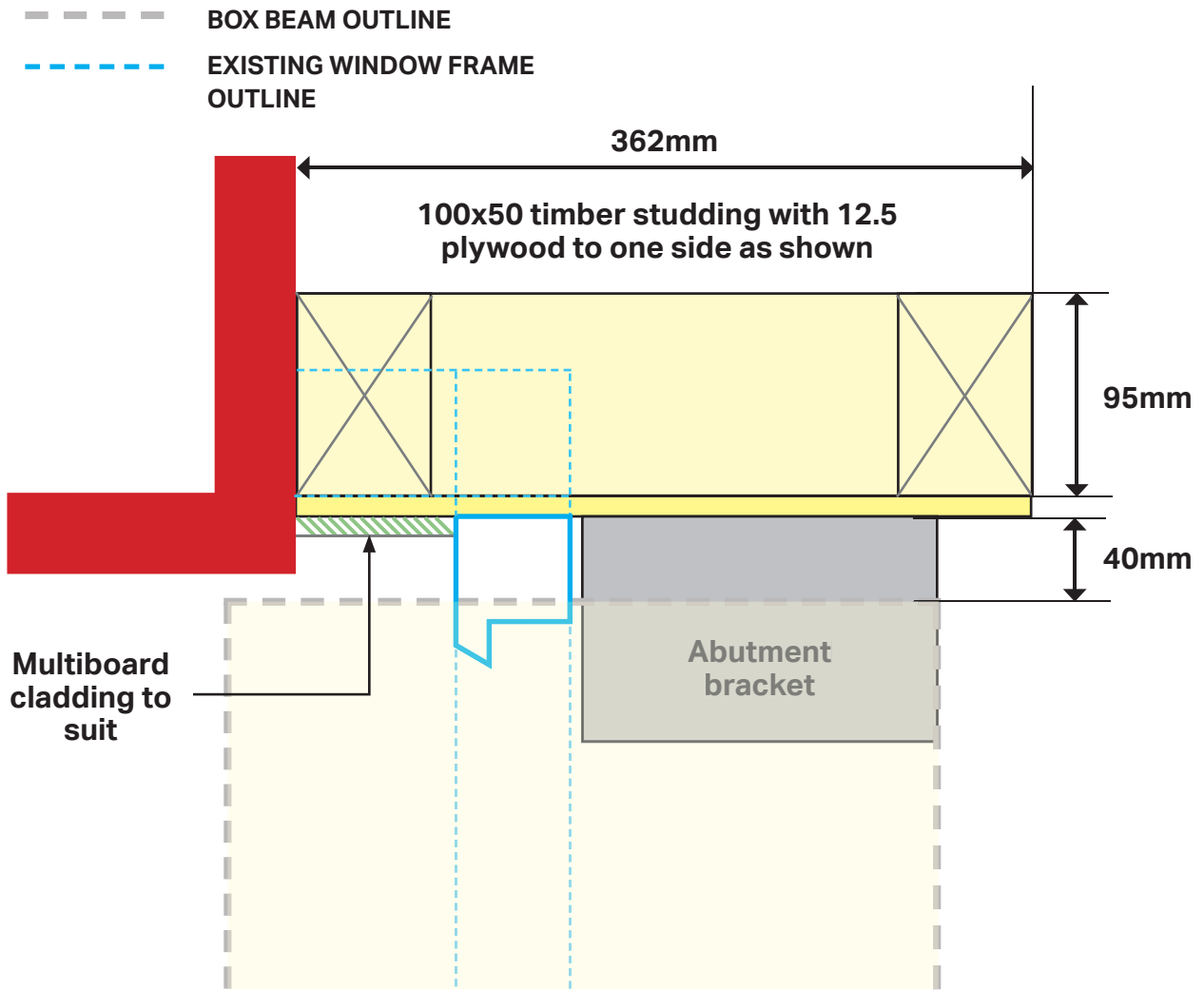

Replace existing frame with 100x50 (MIN) timber studding with 12.5mm plywood to bracket, fixed back to host wall and floor or dwarf wall.

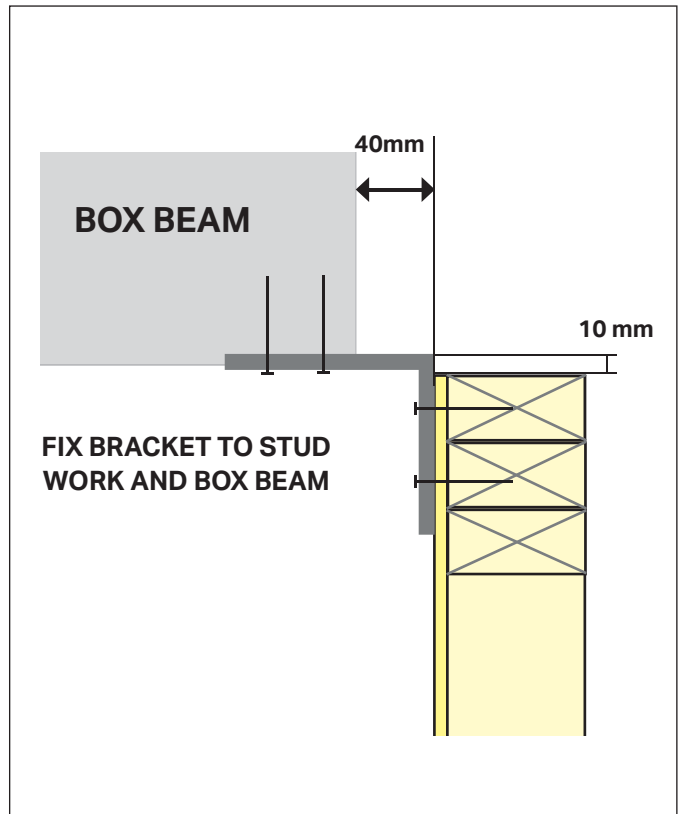
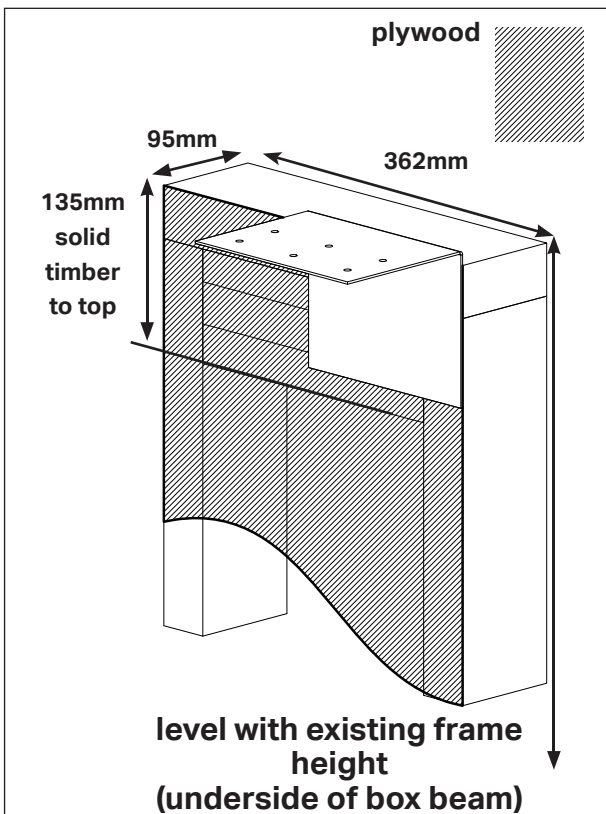

## CONVERTING EXISTING CONSERVATORY WITH BOXGUTTER TO ULTRAROOF380

### 265 BOX GUTTERS

**Extended soffit:** The internal frame line will be 265mm from the host wall, this will result in a gap of 57.5mm down the side of the beam. This gap is packed out with 47.5mm timber and 10mm of box gutter foam. The beam is supported on the wall with abutment bracket, and by fixing to existing conservatory window frames. Finally a tapered box gutter is added, 47.5mm packed off the host wall with timber to line up correctly with the guttering.

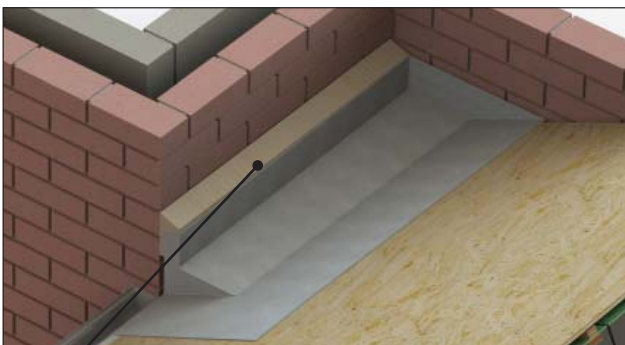
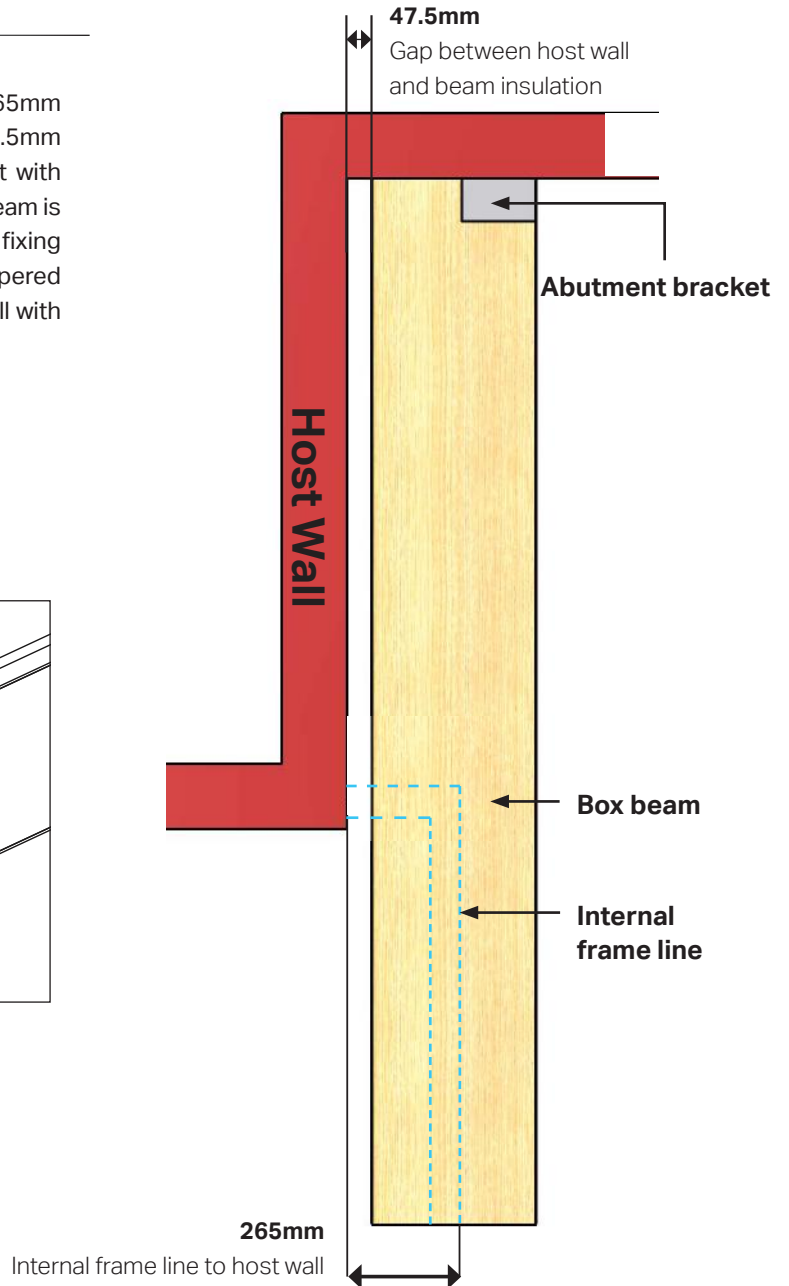
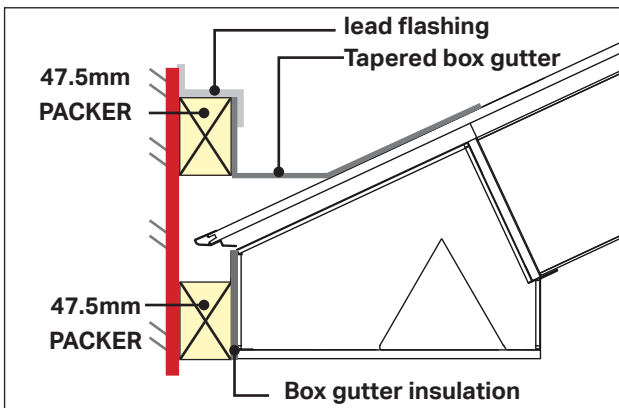

47.5mm packed off Timber has been used to pack off the box gutter to line up with the standard gutter.

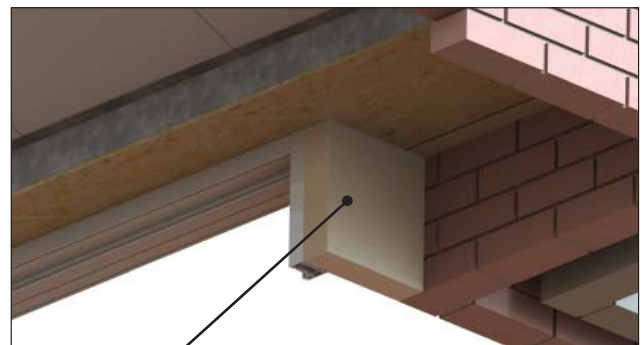

Infill 70 x 265mm In this case infill option is shown as timber.

### APPROPRIATE FIXINGS

The correct selection/specification of fixings for UltraRoof380 is CRITICAL.

Ultraframe recommends HILTI chemical anchors where specified and expanding anchors in other locations (to resist pull out forces). Using HILTI product codes/descriptions, use a HIT-V 80mm x M8 threaded anchor (stud\*) fastened into a 10mm clean drill hole with gun injected mortar or adhesive capsules (with a minimum 80mm embedded) - always rigorously follow the manufacturers guidance [www.hilti.com](http://www.hilti.com)

**In addition Ultraframe recommends the following alternatives; Fischer M8/M10 masonry injection anchor FIS V Rawl Fixings M8/M10 CFS RM50 or CFS RP30.**

\* Design load for each stud 2.5kN

### CAVITY TRAY ASSESSMENT / VERTICAL DPC REQUIREMENT

**It is good practice to undertake a risk assessment to determine IF cavity trays should be retro fitted.**

In zones 1 and 2, cavity tray installation is based upon risk assessment - factors include determining if elevation faces prevailing wind, absorbancy of brickwork and mortar joint type. Cavity trays **MUST** be installed in severe/very severe exposure zones (3 and 4).

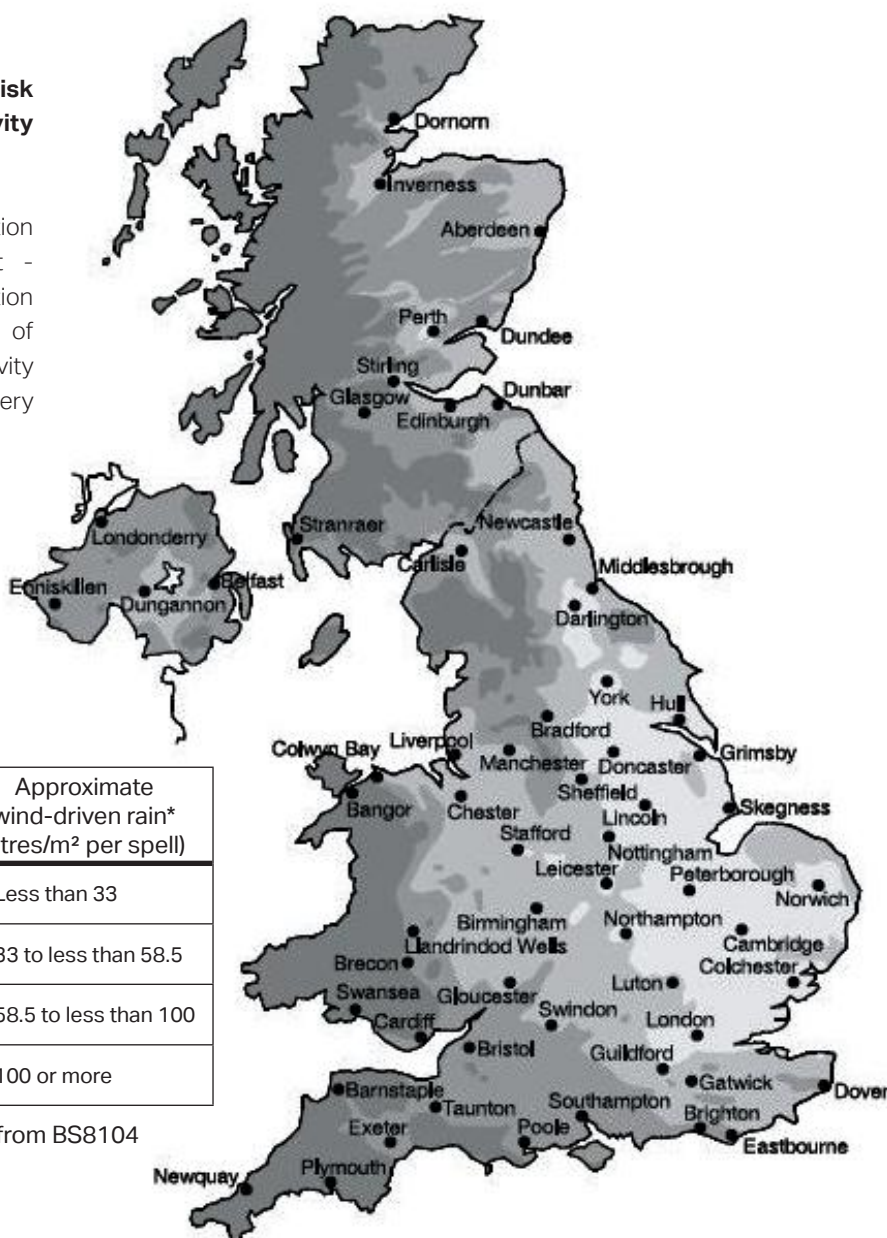

KEY	EXPOSURE ZONES	Approximate wind-driven rain* (litres/m <sup>2</sup> per spell)
	1 Sheltered	Less than 33
	2 Moderate	33 to less than 58.5
	3 Severe	58.5 to less than 100
	4 Very Severe	100 or more

\* Maximum wall spell index derived from BS8104

**ultraframe**  
Transforming light and space

**[www.ultraframe.co.uk](http://www.ultraframe.co.uk)**

Ultraframe (UK) Ltd, Salthill Road, Clitheroe, Lancashire. BB7 1PE