



# QUANTAL

## **PREMIUM ALUMINIUM SYSTEMS**

Atriums, orangeries, glass houses, conservatories and home extensions

# Welcome to QUANTAL



The Quantal aluminium conservatory roofing system offers you a unique solution for atriums, orangeries, glasshouses, conservatories and home extensions.

We specialise in creating custom made, hand finished glazed buildings which offer an engineered solution for all your requirements. Quantal premium aluminium systems appeal to retailers seeking uniqueness and exclusivity and also those who need an aluminium product to satisfy local planners.

Specialising in creating custom made glazed buildings

# QUANTAL



*From the most traditional conservatory through to striking designs for glass extensions Quantal can bring any project to life.*

## Stunning looks, so easy to fit

You may be wondering how we make such a superior product so easy to install?

The product's features not only make installation easy but improve long-term weatherproofing and performance whilst offering unrivalled structural versatility.

Quantal is the **ONLY** aluminium glazed roof system to carry the prestigious BBA Accreditation.



Quantal can bring any project to life



# Specification to fabrication

The Quantal aluminium roof has been independently accredited by the BBA. Quantal undertakes additional structural, weathering and durability testing to ensure you receive THE premium product.



*Quantal is quality through and through - from specification to fabrication.*

Each and every roof is manufactured to the consumer postcode using U-Design software. The software automatically upgrades the specification of the roof, to ensure it is suitable to carry the wind and snow loads at the consumers property.

The Quantal manufacturing facility is the 'leanest' possible, offering the highest level of off site fabrication to ensure fitters on site have a positive 'right first time' experience.

In the unlikely event a site visit is required, Quantal's field based site engineer is just a phone call away. Office based technical support is also on hand to assist in many ways.

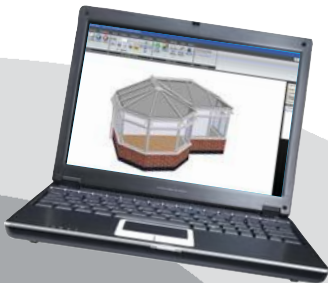
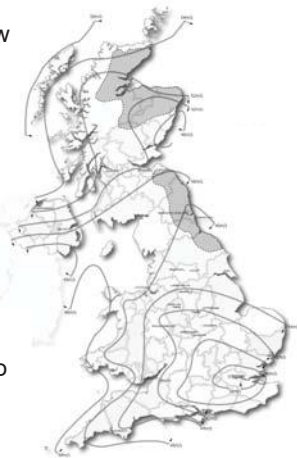

U-Design software automatically chooses the correct specification

## System Overview

*There has been significant investment in the Quantal product and brand, with a new, technically improved and modernised chassis blending with the traditional quality look, feel and finish of the fully aluminium premium Quantal system.*

### Eavesflow (optional)

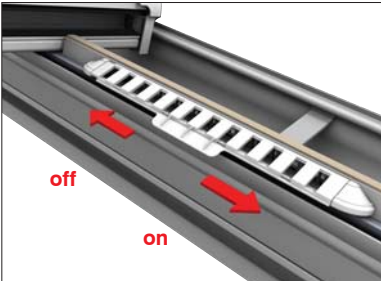
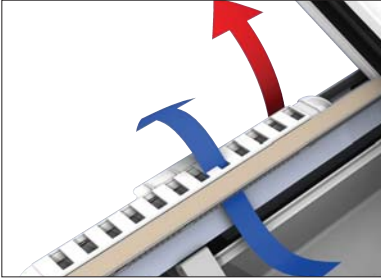

A trim that fits between the wall sideframe and roof, with built-in ventilation and a slider on/off control button.

**The system is now more configurable and easier to fit.**

Just some of the great features;

- All aluminium externally yet thermally sleeved to optimise homeowner comfort
- Now featuring optional Eavesflow trickle ventilation at the eaves
- Various eaves options to achieve 2½ degree\* lean-to's, and a reinforced version for gables and over wide opening doors
- Chambered combi eaves and box gutter, foam insulation wrapped for enhanced thermal performance and to virtually eliminate condensation
- A full suite of glazing bars – including a wide span version – ensures you only pay for the span performance you need
- Jack rafter tenon sleeves into chambered aluminium jack rafter and is retained by triple fixings before multi point fixing to hip bar
- Speedlok attachment to die cast end offers ultimate flexibility in glazing bar attachment, offering perfect glazing alignment and perfect water proofing with the 'soft touch' weathering seal

**Read on for even more.....**

# At the heart of the system

The Quantal Aluminium Roof is beautifully detailed, robustly engineered and offers unrivalled structural performance and long term weather proofing.

## Standard eaves assembly

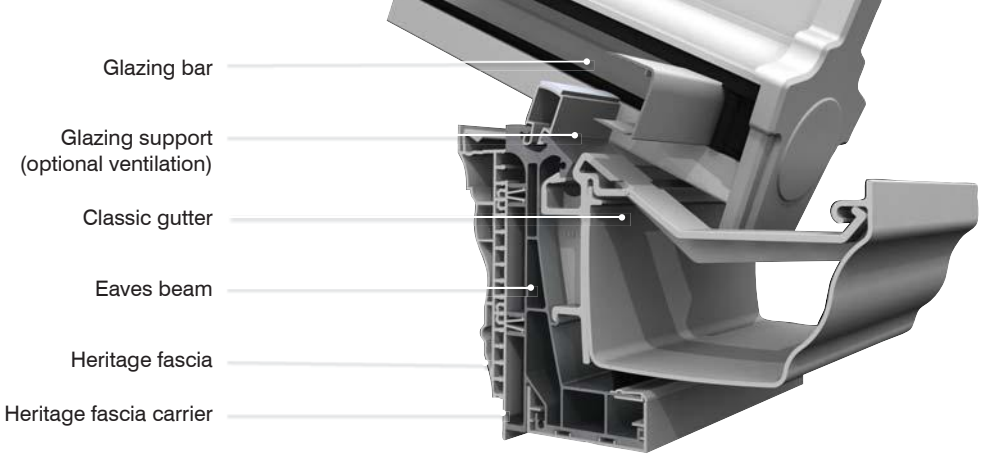

## Wall plate assembly

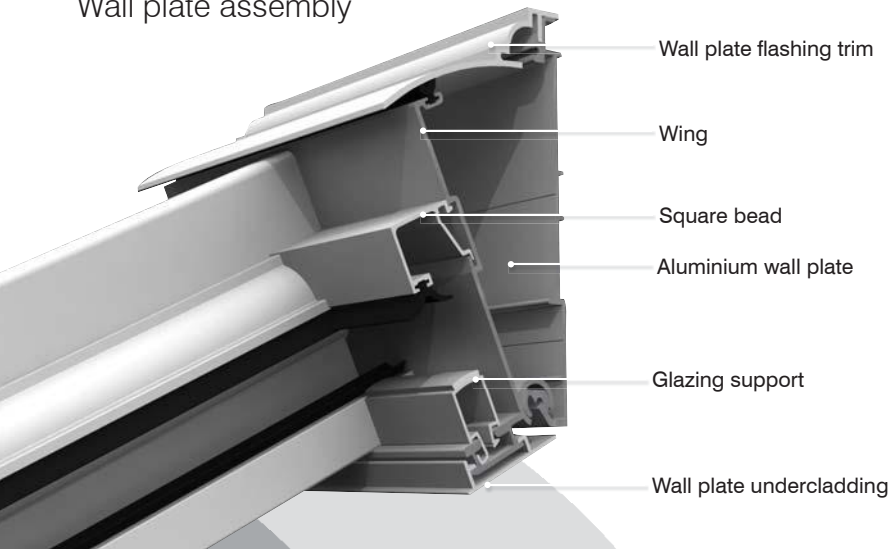

Stunning looks - so easy to fit

# QUANTAL

## Valley & boxgutter main assemblies

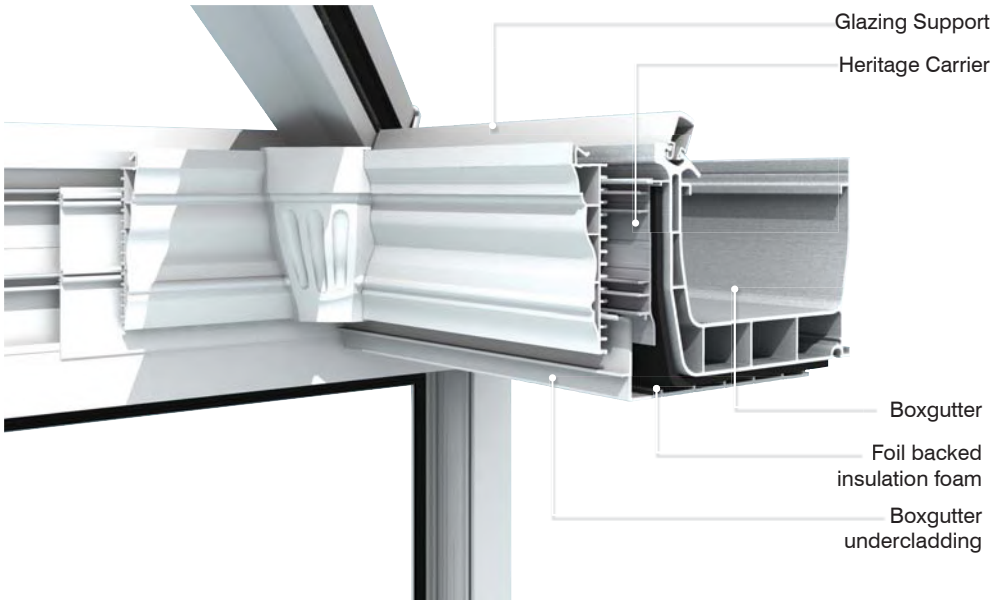
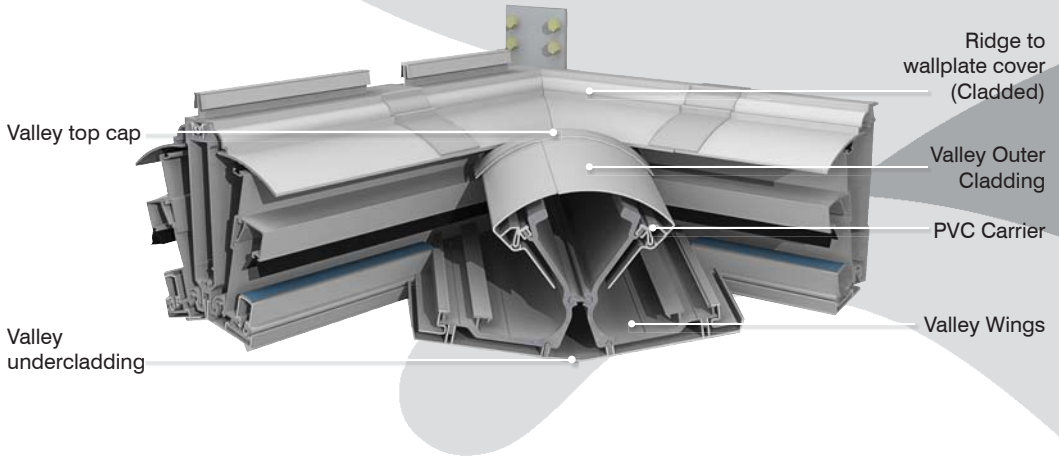

Stunning looks - so easy to fit

Ridge Ends

Britannia finial

Gallery top cap

Radius end seal



Front screen

Speedlok  
Radius end

Radius end internal cap

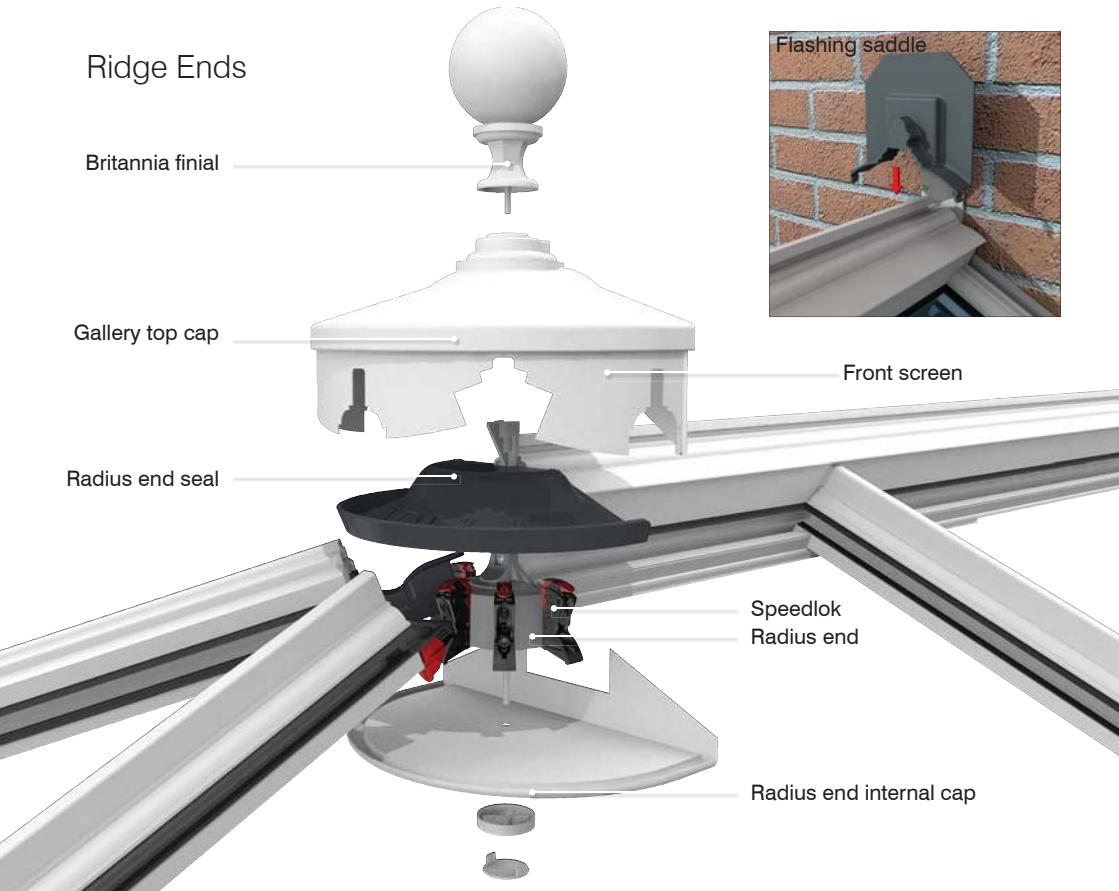

Bar End

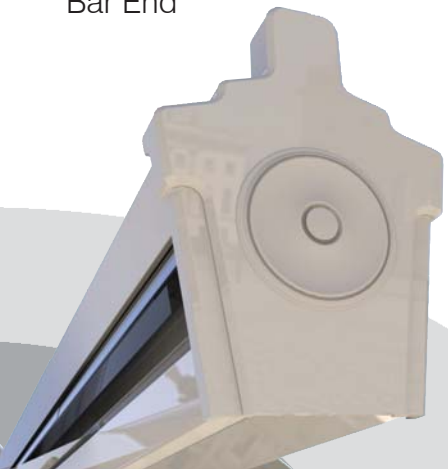

Glass Stop



Unrivalled structural performance, long term weatherproofing



# QUANTAL

## Uni Ridge (20°-30°)

Uni Ridge body

Gaskets

Glazing support

Internal Cladding

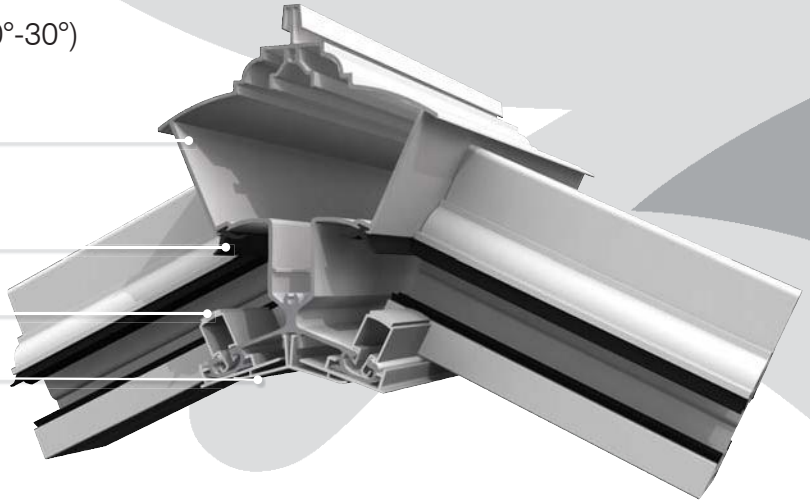

## Variable (clip on) Ridge (15°-40°)

Ridge capping (clip on)

Ridge body

Wing

Square bead

Glazing support

Internal Cladding

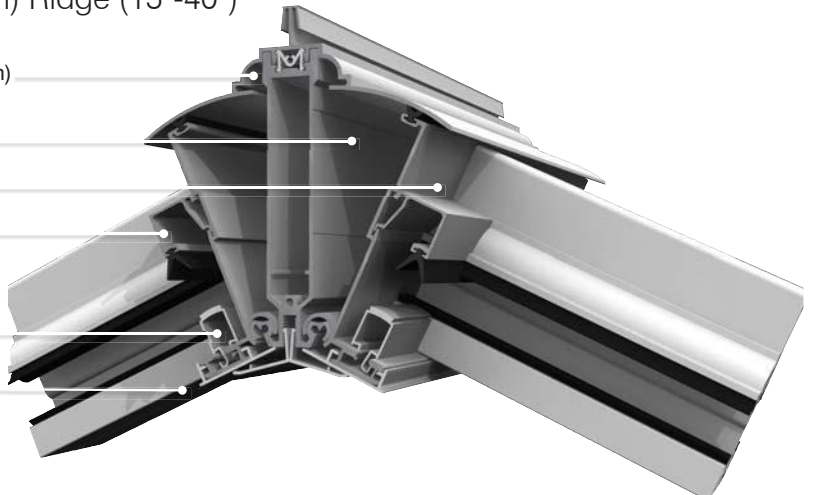

Unrivalled structural performance, long term weatherproofing

# Widespan bar

The **Widespan** glazing bar is purpose designed for lean-to and hipped lean-to conservatories, responding to the increasing requirements for conservatories large enough to significantly increase living space in the home or to add extra space in commercial buildings.

**Widespan** can reduce the need for portal frames, purlins or bolster bars; improving the all round aesthetics, substantially reducing costs and making for faster, easier installation on these bigger projects.

With a span increase of 25% it enables projections of 4.15 metres at 700mm centres with glass and projections of up to 5.25 metres can be achieved with ease with polycarbonate glazing.

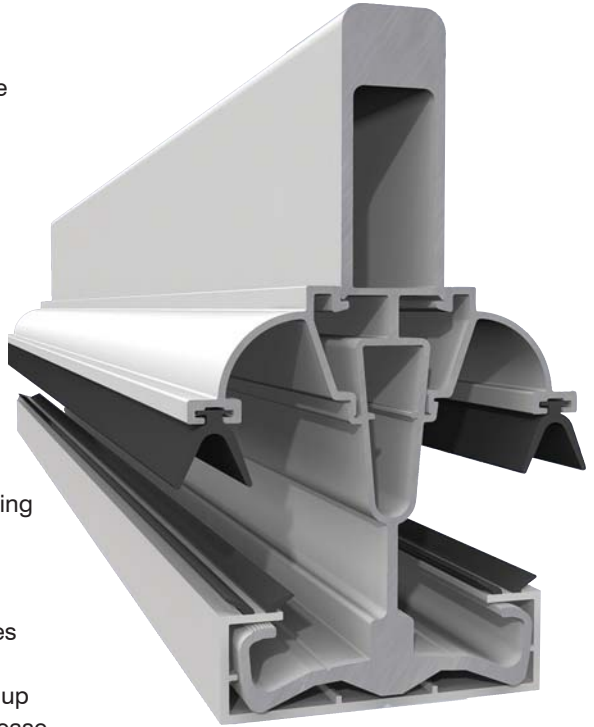

## Quantal WIDESPAN Key Features

- Lean-to or duo pitch designs
- 25% increase in spans
- Up to 5.25 metre projections - poly
- Reduction in need for portal frames
- Installation as per standard bar



Extra Heavy Duty Lean-To Glazing Bar - saves on portal frames/goalposts

# QUANTAL

## Re-inforced Eaves

The ideal solution for Bi-fold doors in glazed extensions



The bolstered eaves ensures you can easily incorporate a Bi-folding door without affecting the Bi-fold door's operating mechanisms on regular projects. The Quantal Bi-fold Eaves eliminates the need for unsightly and costly steel structures to support door openings. Quantal provide a truly engineered solution without affecting the internal or external aesthetic.

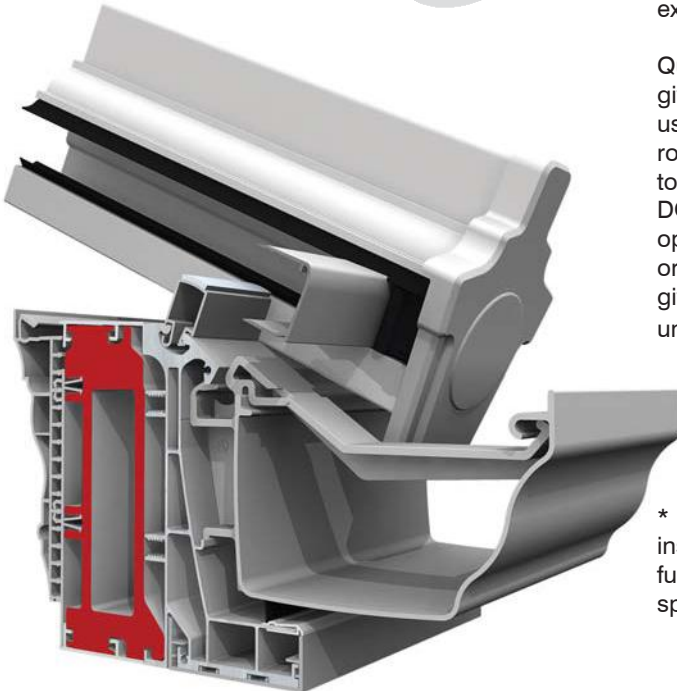

Quantal's Bi-fold Eaves can give you up to 4.3m openings using polycarbonate as your roof glazing material, or up to 4.0m using a standard DGSU. This will provide an opening to fit typically a 4 or 5 panel Bi-folding door, giving the homeowner lavish uninterrupted views.

\* Further options include the insertion of rolled steels to further increase unsupported spans.

This popular option seamlessly helps with the fitment of wider doors

# Other Options

---

## Heritage Architrave

The adjustable internal eaves beam cladding system brings the superior aesthetics of the Quantal roof inside. Available with internal and external corner trims the clip on cladding offers variable height settings to speed up installation.

Available in white or foiled finishes the Heritage Architrave is a perfect match for all frame types.



## Roof Vent

Primary ventilation can be introduced using the gasketed thermally broken aluminium roof vent. Choose from manual operation or climate control electric pack.

The roof vent is fully BBA certified and tested to 300 pascal water tightness

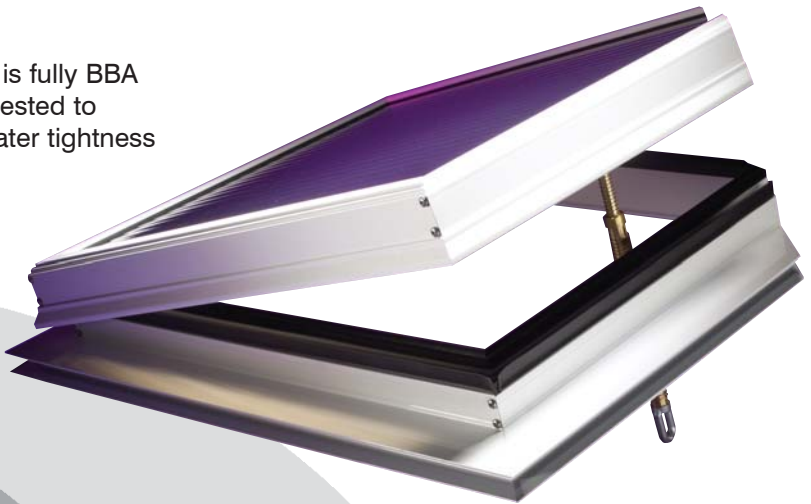

Choice of detailing at the internal eaves & primary ventilation



## Cornice

Create smooth clean lines at the eaves interface externally.

The addition of an aluminium Cornice is a stunning option that can really add individual style to a conservatory, sunroom or Loggia home extension. The elaborate detailing adds height and presence and produces a spectacular impression of design finesse and architectural integration

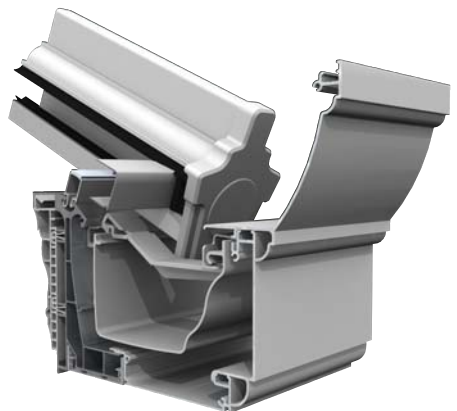

Creating smooth clean lines at external eaves.

# LivingRoom

---

The conservatory that thinks it's an extension.  
Welcome to LivingRoom

LivingRoom adds an engineered framing system internally which is plastered to give a perimeter ceiling all the way round.

This creates something that is both conservatory and extension.

- 15-40° pitch, unequal pitches are accommodated
- Choose variable internal projection, from 300-1200mm
- Comes with 25mm heatguard polycarbonate 'cloaking screen'
- 0.6 'U' value improves thermal comfort (option on site to add 120mm mineral wool quilt to improve 'U' value to 0.2).
- Use on side frames, brick piers or super insulated Loggia columns (p18).



LivingRoom is Quantal's cost effective orangery solution

# QUANTAL

## Colour

The optional features of Quantal's unique authentic period style aluminium roof with traditional solid cast crestring and finial are ideally suited for creating a truly stunning coloured glazed roof.

Coloured roofs are particularly suitable for enhancing the heritage feel of distinguished period properties.



## Infinite Choice

All our aluminium and internal cladding components can be coloured in any RAL or BS shade to allow customers an infinite choice across the whole range of conservatory designs.

Using our purpose built in house paint shop we 'spray and bake on' at 60° using the same high-grade acrylic formulation and technology employed on modern car bodywork.

The result is a totally colourfast and durable finish, fully guaranteed.



## Reference the RAL

Colour chart to check out the source colours.



Choose from any RAL or BS shade - the ultimate in choices

# Atriums

The Quantal aluminium atrium is perfect for new build or refurbishment. When specified RAL 7016 (grey) it ensures the rooflight atrium blends into the surrounding roofscape.

Internally, the room below is flooded with light. A rooflight atrium allows for higher proportions of ceiling when compared to traditional orangeries - and the Quantal rooflight atrium (available from 'stock' in white - plus a range of other RAL colours) can be fitted 'in series' across a large flat roof.

Atrium roofs feature a low height eaves beam which is fastened to a timber kerb or low height lantern frames. This improves thermal performance by reducing the potential of cold bridging.

If a gutter is required or if the Heritage internal cladding is required, then the roof is upgraded to the standard eaves with a height of 118mm.



An interesting alternative to a full orangery system



# Choosing the right glass for you

# QUANTAL

Quantal supplies a range of high specification double glazed sealed units to offer a 'one stop shop' for the ultimate glazed roof solution.

|                    | Self Cleaning |                |             |            | Anti Sun (1.1) |      |        | Anti Sun(1.5) |         |         | Clear |         |
|--------------------|---------------|----------------|-------------|------------|----------------|------|--------|---------------|---------|---------|-------|---------|
| Code               | Pilkington    |                |             | St. Gobain | A1             | A2   | A3     | B1            | B2      | B3      | C1    | C2      |
|                    | SB            | NC             | CL          | GR         |                |      |        |               |         |         |       |         |
| Colour             | Activ Blue    | Activ Neutral* | Activ Clear | Aqua Green | Blue           | Grey | Bronze | Blue          | Grey    | Bronze  | Clear | Clear   |
| 'U' value          | 1.1           | 1.1            | 1.1         | 1.1        | 1.1            | 1.1  | 1.1    | 1.5 (K)       | 1.5 (K) | 1.5 (K) | 1.1   | 1.5 (K) |
| Solar Rejection    | 64%           | 63%            | 41%         | 73%        | 60%            | 57%  | 56%    | 55%           | 49%     | 47%     | 37%   | 28%     |
| Light Transmission | 52%           | 44%            | 75%         | 40%        | 57%            | 50%  | 54%    | 53%           | 47%     | 51%     | 80%   | 75%     |
| Self Cleaning      | Yes           | Yes            | Yes         | Yes        | No             | No   | No     | No            | No      | No      | No    | No      |
| Spacer (Aluminium) | Yes           | Yes            | Yes         | Yes        | Yes            | Yes  | Yes    | Yes           | Yes     | Yes     | Yes   | Yes     |
| Gas (Argon)        | Yes           | Yes            | Yes         | Yes        | Yes            | Yes  | Yes    | Yes           | Yes     | Yes     | Yes   | Yes     |
| 24mm* (4-16-4)     | Yes           | Yes            | Yes         | Yes        | Yes            | Yes  | Yes    | Yes           | Yes     | Yes     | Yes   | Yes     |
| 10yr Guarantee     | Yes           | Yes            | Yes         | Yes        | Yes            | Yes  | Yes    | Yes           | Yes     | Yes     | Yes   | Yes     |

## Specification

- All units are 4-16-4 toughened, gas filled and come with silver aluminium spacer as standard (bronze, dark bronze, gold & white also available). Super spacer option available.

## Self Cleaning

- True self cleaning (Not a temporary spray on coating)
- Keeps out nearly three quarters of the sun's heat energy
- Choose from:
  - Pilkington Activ in blue or neutral (solar control)
  - Pilkington Activ clear (NOT solar control)
  - Saint Gobain aqua green (solar control)

## Anti Sun/Clear

- Choose Anti Sun blue, grey, bronze or standard clear units
- Option of soft coat low e (1.1) or K glass (1.5) on the inner leaf



**ASK ABOUT  
OUR VERY  
LATEST  
RANGES**

One stop shop - seamless ordering, no mis measures

# Loggia from Quantal

## Loggia - the conservatory redefined

Loggia is the best of all worlds with light and sky and solid plastered walls. Loggia consists of exciting and innovative elements, namely super insulated columns (0.15 'U' Value) and the LivingRoom internal perimeter ceiling. With its aluminium roof, aluminium cornice and powder coated Loggia columns, Quantal is offering the ultimate aluminium home extension building system.

Ask to see the separate Loggia Range brochure and explore the full potential Loggia delivers.

Quantal roof with  
Cornice which sits on top

Insulation core is styropor carbon  
enriched expanded polystyrene

OSB board to all sides mechanically  
fixed to battens (wrapped in beathable  
membrane)

Powder coated aluminium claddings  
in a range of 4 standard colours

Various base details available

Structural set out post

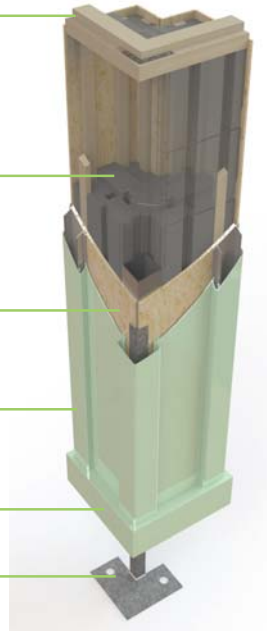

EXPANDING YOUR SALES OPPORTUNITIES - see separate brochure.

# Commercial projects

# QUANTAL

The Quantal aluminium glazed roof system can also be used in commercial projects - illustrated below are just a 'snap shot' of recent projects - from single glazed canopies to Listed Buildings,

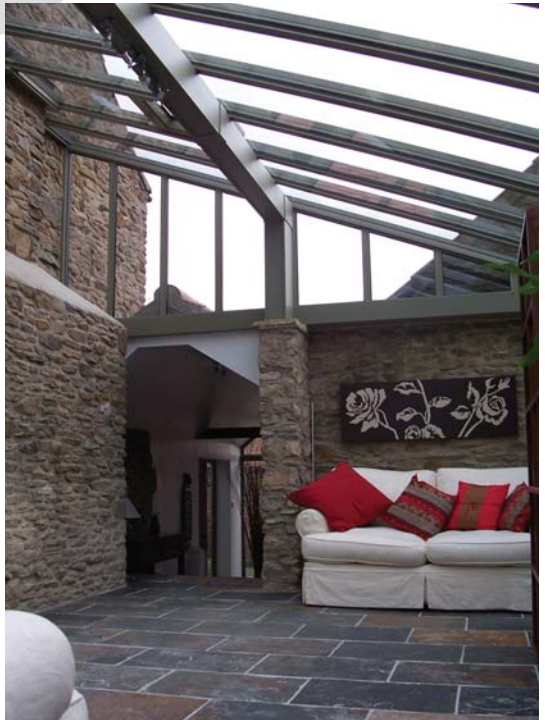

The Quantal aluminium roof can be used in exciting commercial projects

# QUANTAL



For more information visit us at [www.quantal.co.uk](http://www.quantal.co.uk)

Tel: 0843 208 6930 Fax: 0843 208 6931

Email: [sales@quantal.co.uk](mailto:sales@quantal.co.uk)

**Quantal Limited**, Salthill Road, Clitheroe, Lancashire BB7 1PE